

(12) **United States Patent**  
**Hoffmann**

(10) **Patent No.:** **US 11,365,902 B2**  
(45) **Date of Patent:** **Jun. 21, 2022**

(54) **SOLAR OVEN POSITIONING**

(71) Applicant: **Thomas Mark Hoffmann**, Santa Cruz, CA (US)

(72) Inventor: **Thomas Mark Hoffmann**, Santa Cruz, CA (US)

(\* ) Notice: Subject to any disclaimer, the term of this patent is extended or adjusted under 35 U.S.C. 154(b) by 0 days.

(21) Appl. No.: **17/243,388**

(22) Filed: **Apr. 28, 2021**

(65) **Prior Publication Data**

US 2021/0247106 A1 Aug. 12, 2021

**Related U.S. Application Data**

(60) Continuation-in-part of application No. 16/272,053, filed on Feb. 11, 2019, now abandoned, which is a continuation of application No. 15/474,917, filed on Mar. 30, 2017, now Pat. No. 10,247,447, which is a division of application No. 13/916,499, filed on Jun. 12, 2013, now Pat. No. 9,644,864.

(60) Provisional application No. 61/774,563, filed on Mar. 7, 2013.

(51) **Int. Cl.**

*F24S 20/30* (2018.01)  
*F24S 50/20* (2018.01)  
*F24S 30/452* (2018.01)  
*F24S 30/20* (2018.01)

(52) **U.S. Cl.**

CPC ..... *F24S 20/30* (2018.05); *F24S 30/20* (2018.05); *F24S 30/452* (2018.05); *F24S 50/20* (2018.05); *Y02A 40/926* (2018.01); *Y02B 10/20* (2013.01); *Y02B 40/18* (2013.01); *Y02E 10/47* (2013.01)

(58) **Field of Classification Search**

CPC ..... *F24S 20/30*; *F24S 30/20*; *F24S 30/452*;  
*F24S 50/20*; *Y02A 40/926*; *Y02B 10/20*;  
*Y02B 40/18*; *Y02E 10/47*  
USPC ..... 126/714  
See application file for complete search history.

(56) **References Cited**

U.S. PATENT DOCUMENTS

2,913,583 A 11/1959 Regnier et al.  
4,147,154 A \* 4/1979 Lewandowski ..... G01S 3/7861  
126/593  
4,172,739 A 10/1979 Tassen  
4,619,244 A \* 10/1986 Marks ..... F24S 30/48  
126/618  
6,005,236 A 12/1999 Phelan et al.  
6,688,303 B2 \* 2/2004 Davenport ..... F24S 50/00  
126/572  
6,731,250 B1 \* 5/2004 Berman ..... H01Q 1/1221  
343/883  
8,587,775 B1 11/2013 Wilson et al.

(Continued)

*Primary Examiner* — Avinash A Savani

(74) *Attorney, Agent, or Firm* — Douglas L. Weller

(57) **ABSTRACT**

To position a solar oven radiation collection device, a structural extension assembly extends in a radial direction with respect to a structure. A moveable transport provides linear movement of the solar oven radiation collection device along an axis of the structural extension assembly. A linear deploy electric motor is used to control linear movement of the solar oven radiation collection device along the axis of the structural extension assembly. A solar altitude electric motor is used to adjust orientation of the solar oven radiation collection device to take into account changes in solar altitude with respect to time. A solar azimuth electric motor is used to adjust orientation of the solar oven radiation collection device to take into account changes in azimuth with respect to time.

**16 Claims, 29 Drawing Sheets**

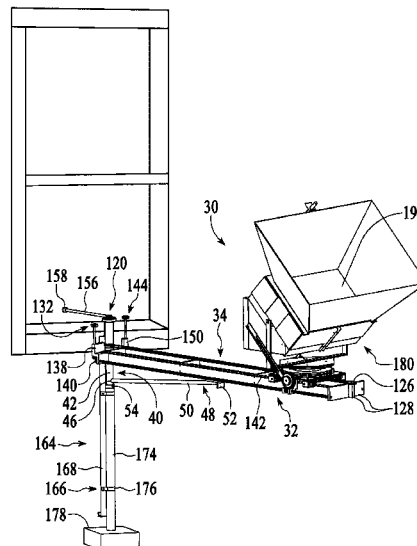

(56)

**References Cited**

U.S. PATENT DOCUMENTS

2013/0000693	A1*	1/2013	Waterhouse .....	F24S 25/13 136/246
2013/0084040	A1*	4/2013	Scott .....	F21S 11/00 385/33
2014/0230804	A1*	8/2014	Siddiqui .....	F24S 50/20 126/576

\* cited by examiner

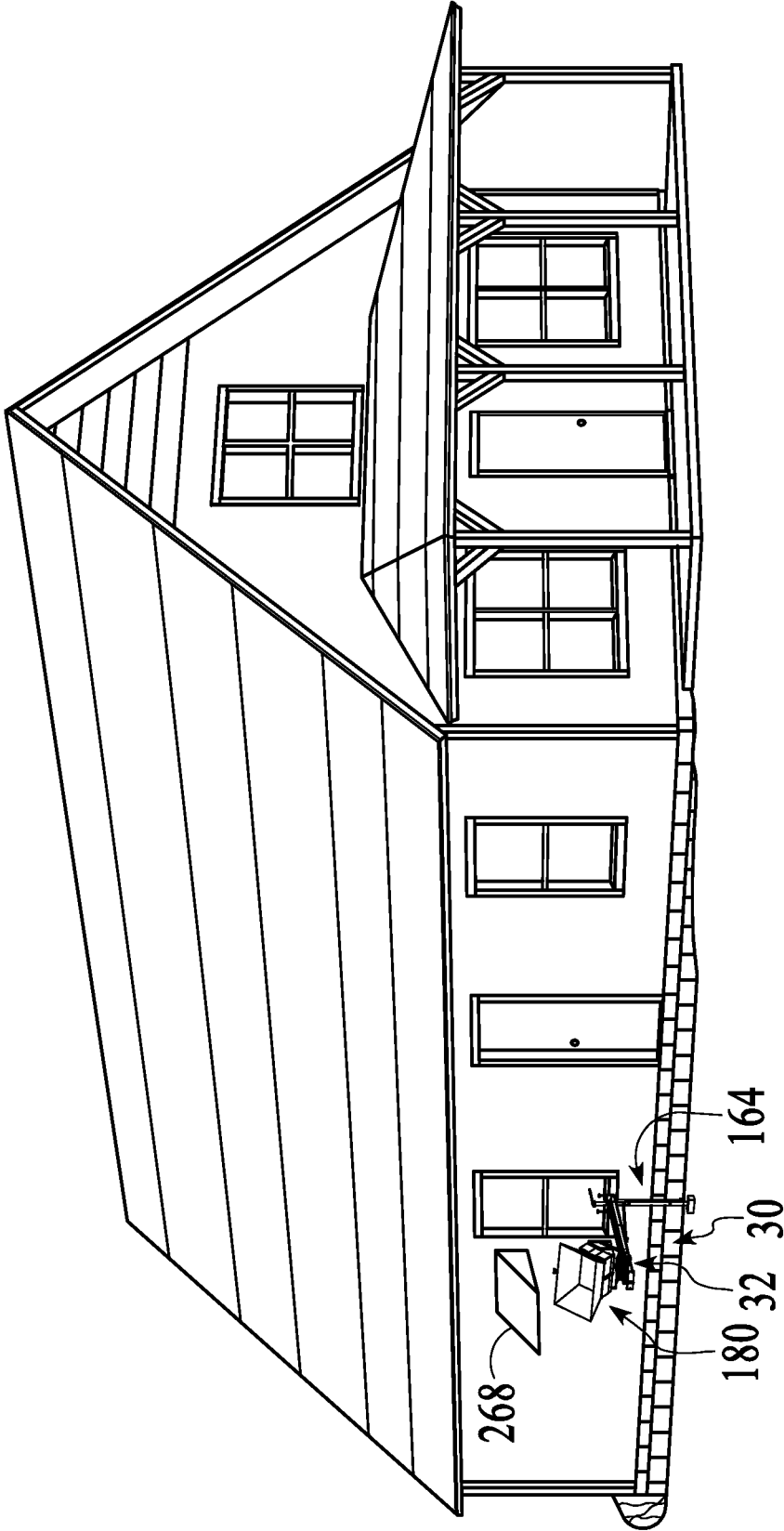

FIG. 1

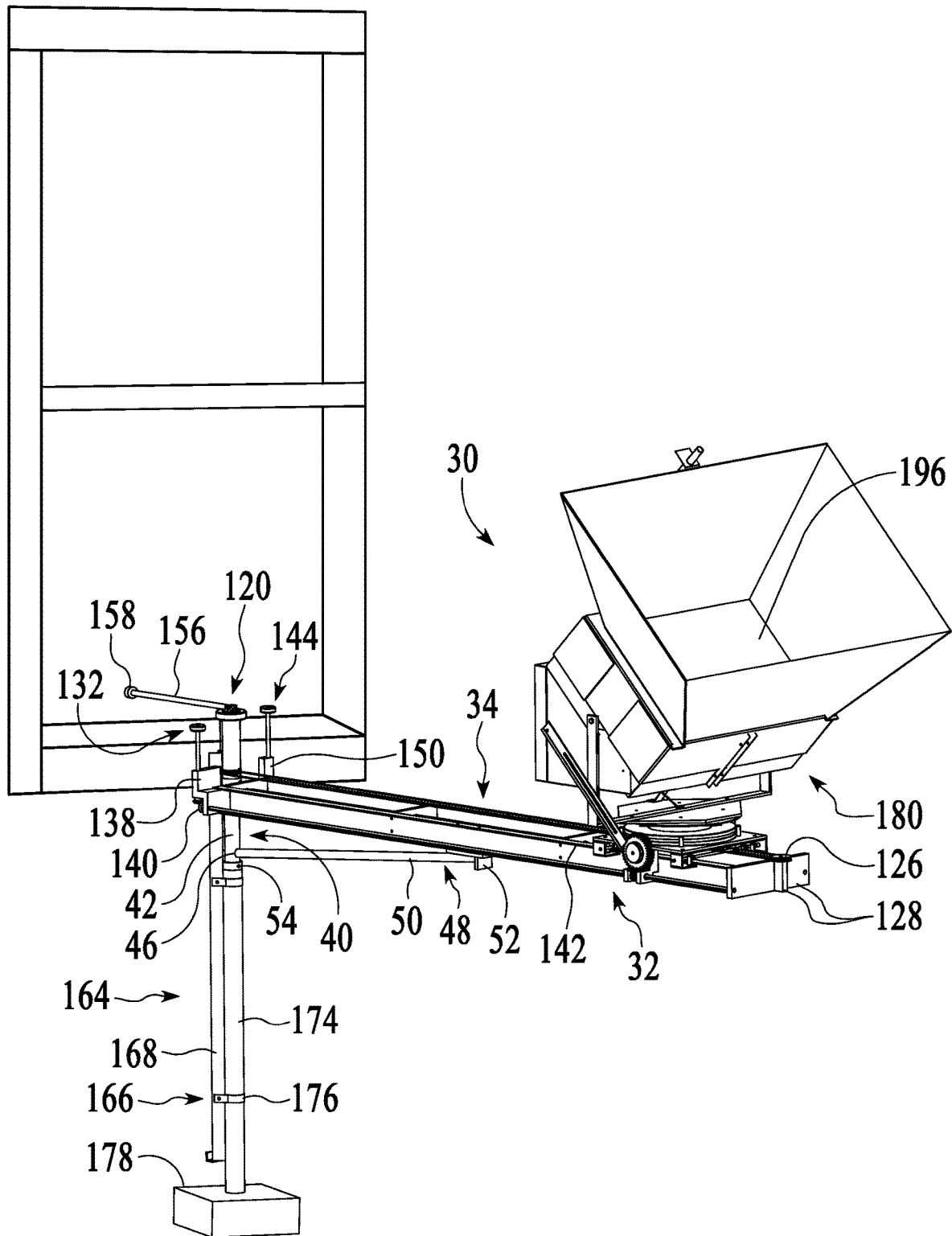

FIG. 2

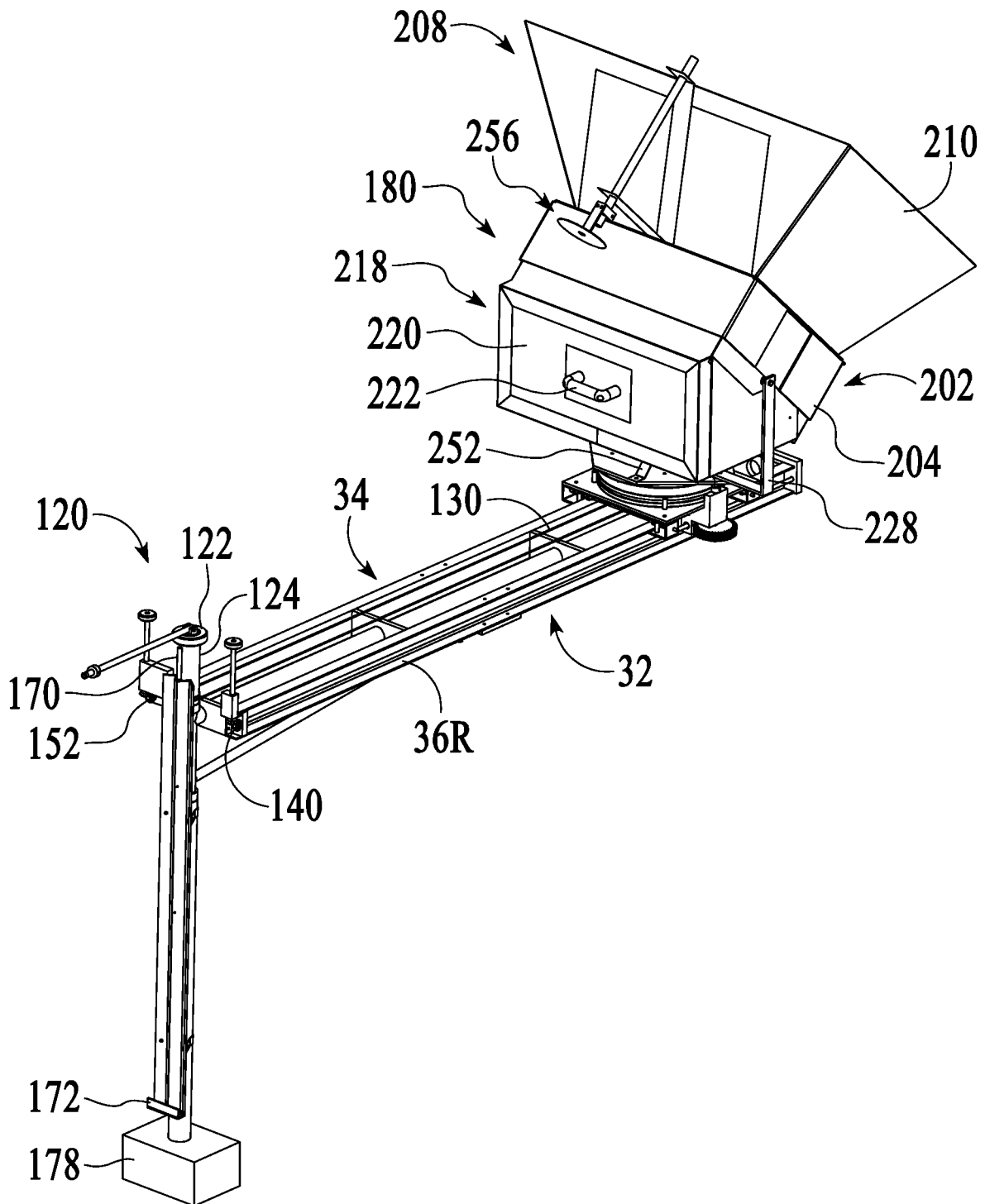

FIG. 3

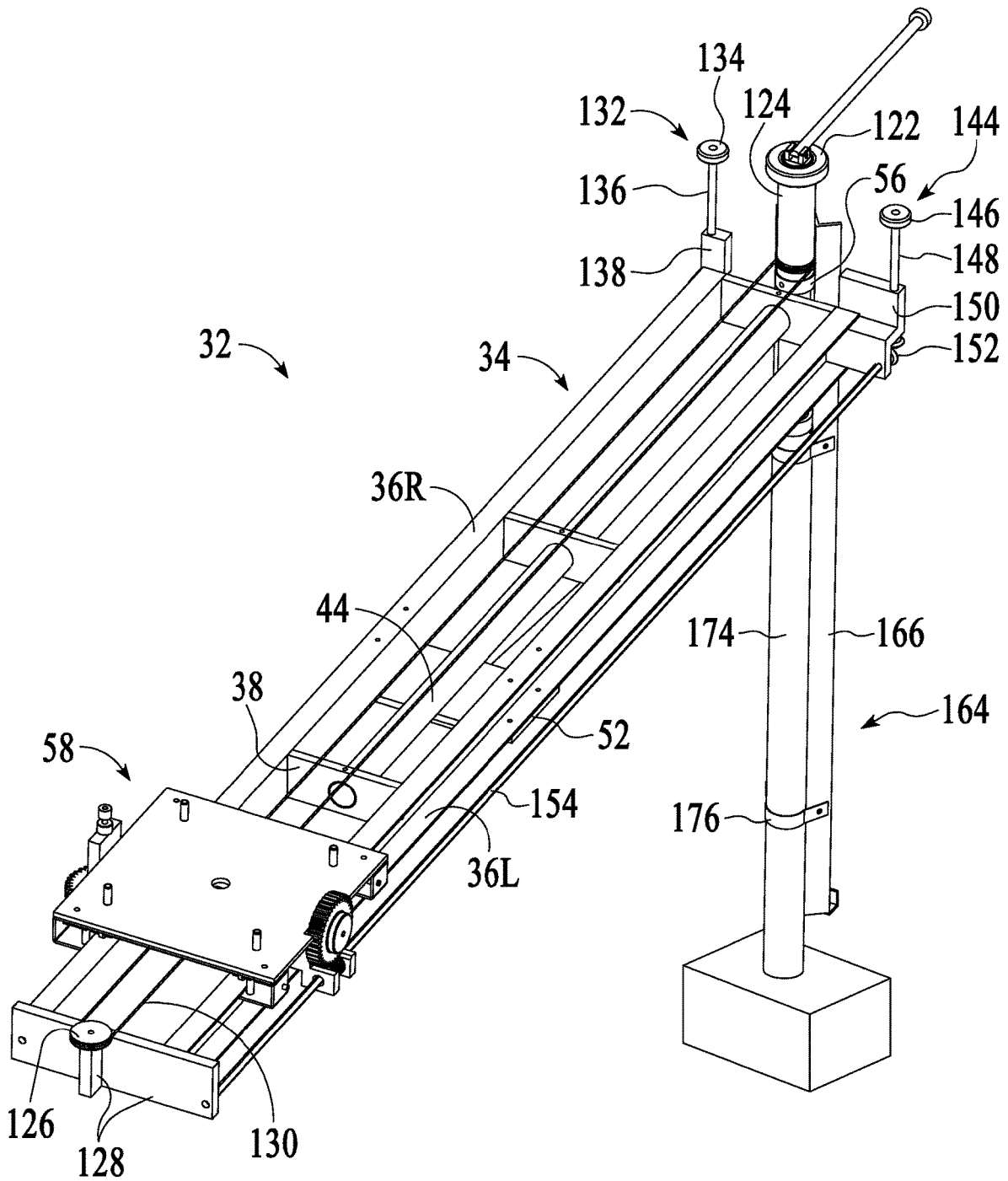

FIG. 4

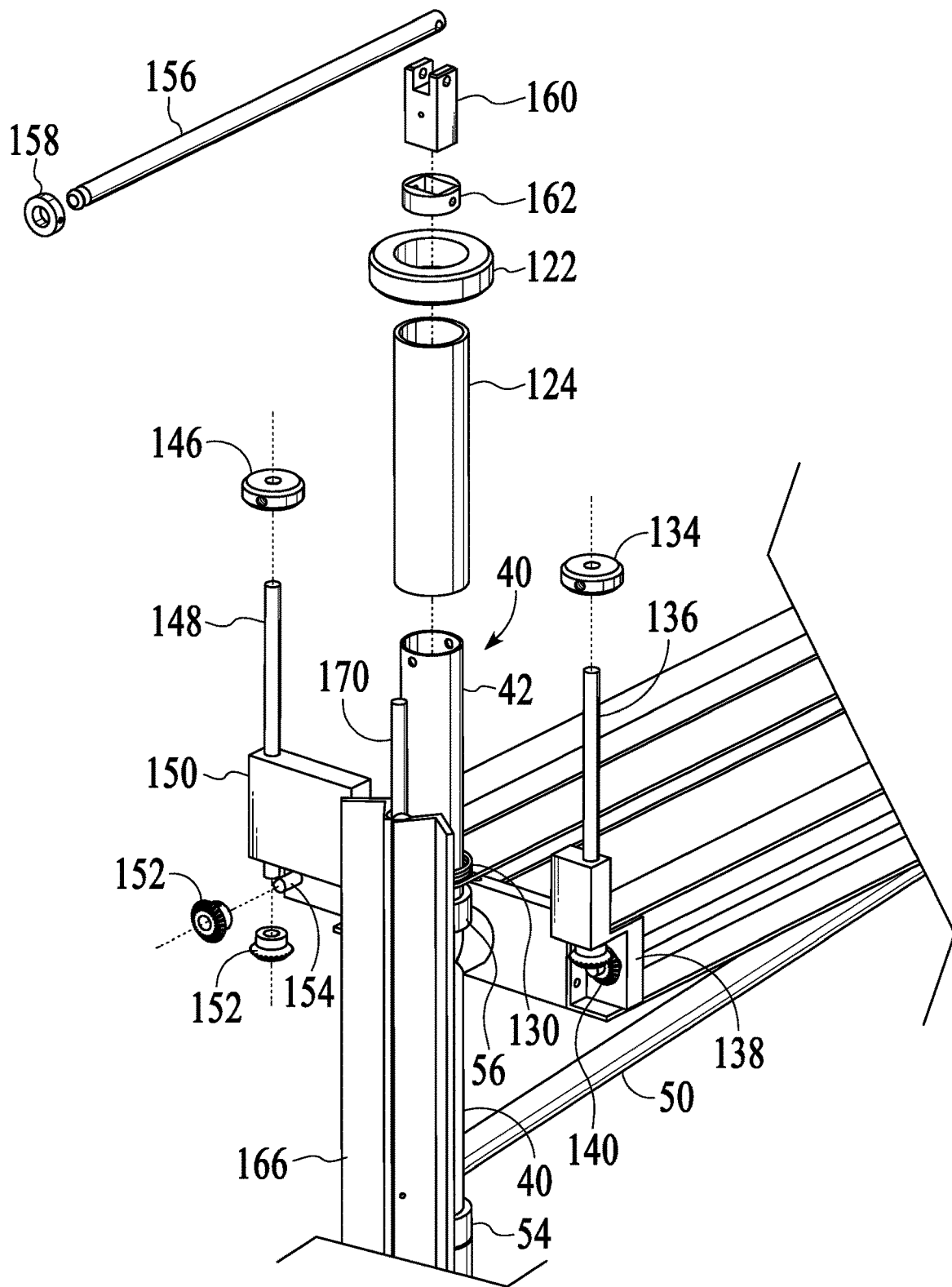

FIG. 5

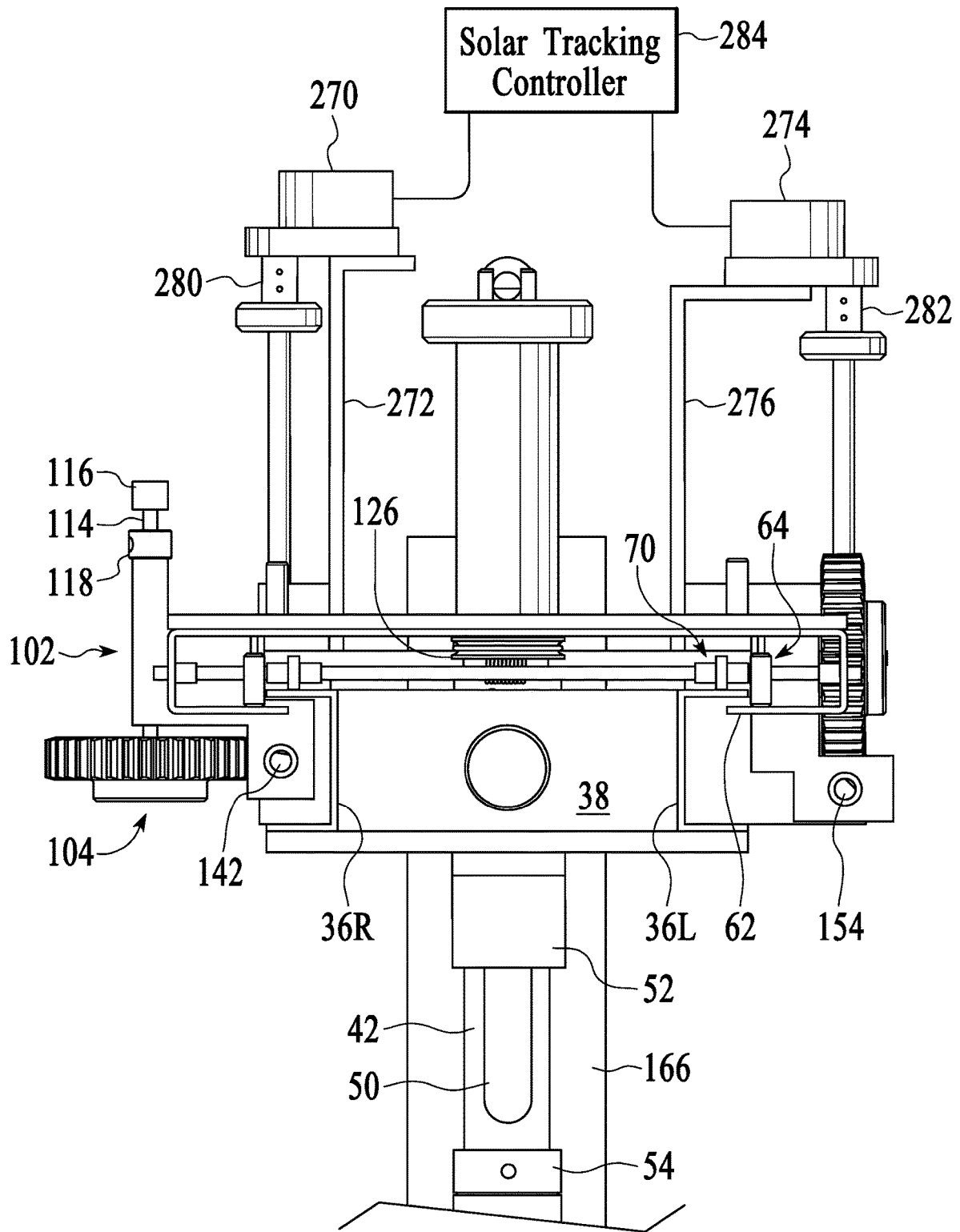

FIG. 6



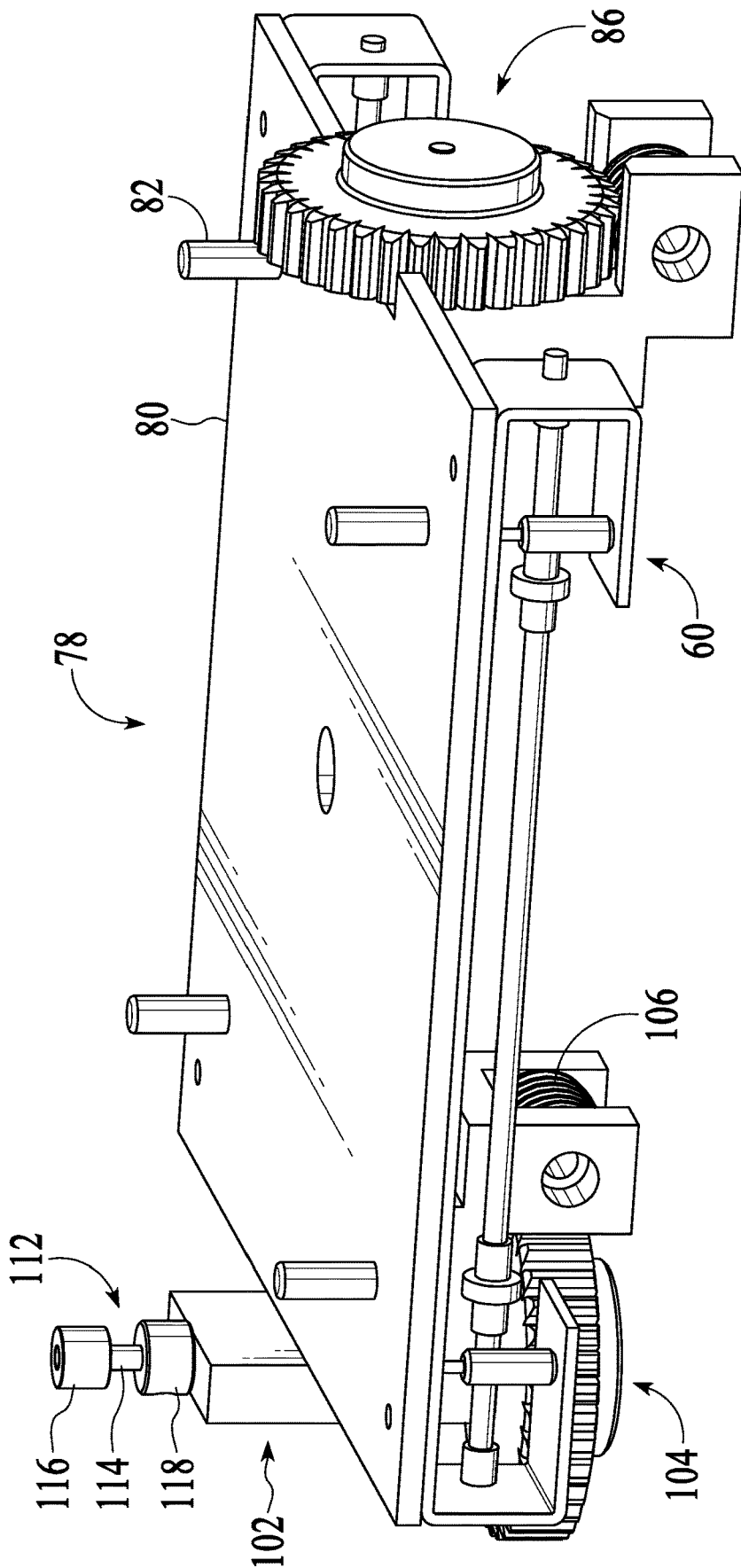

FIG. 7

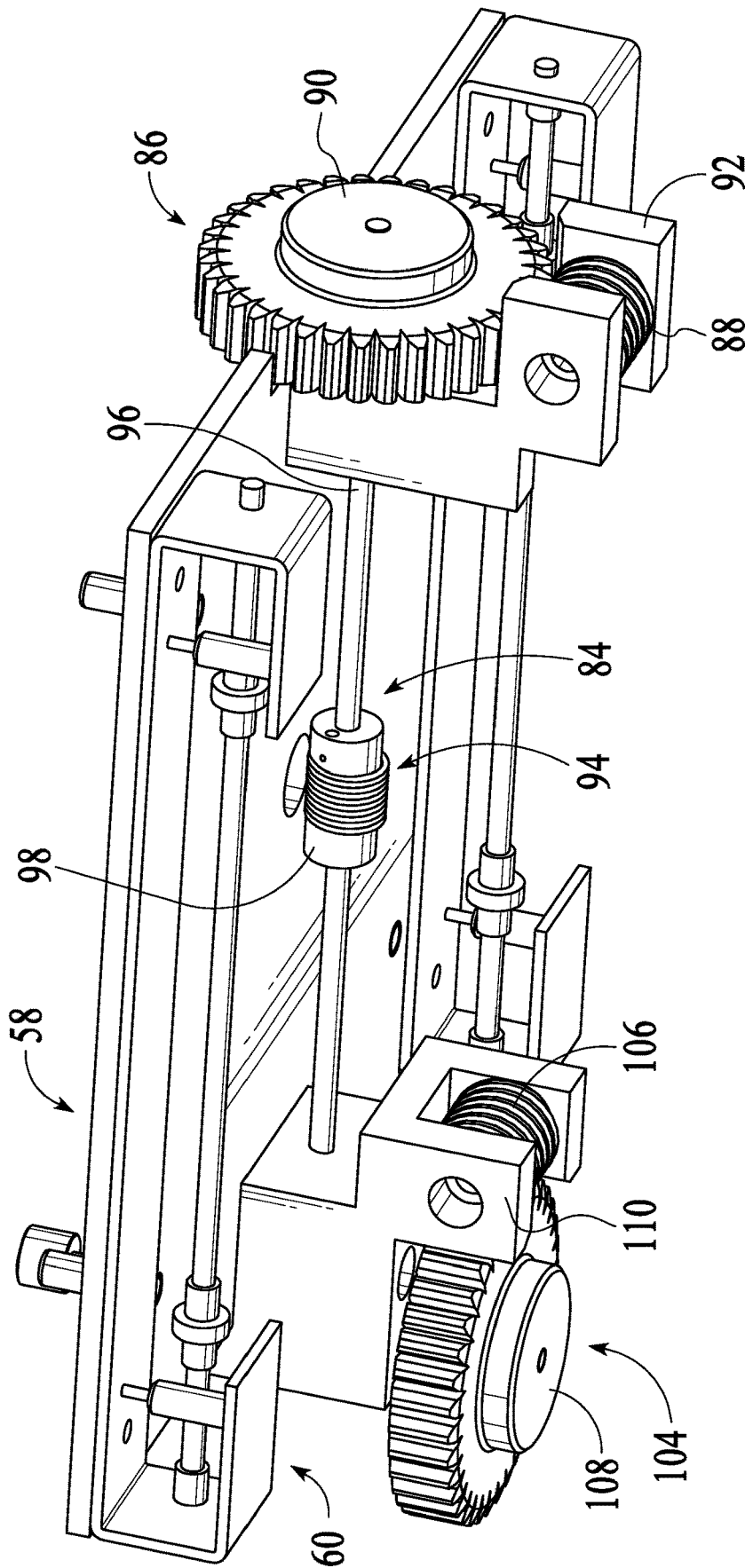
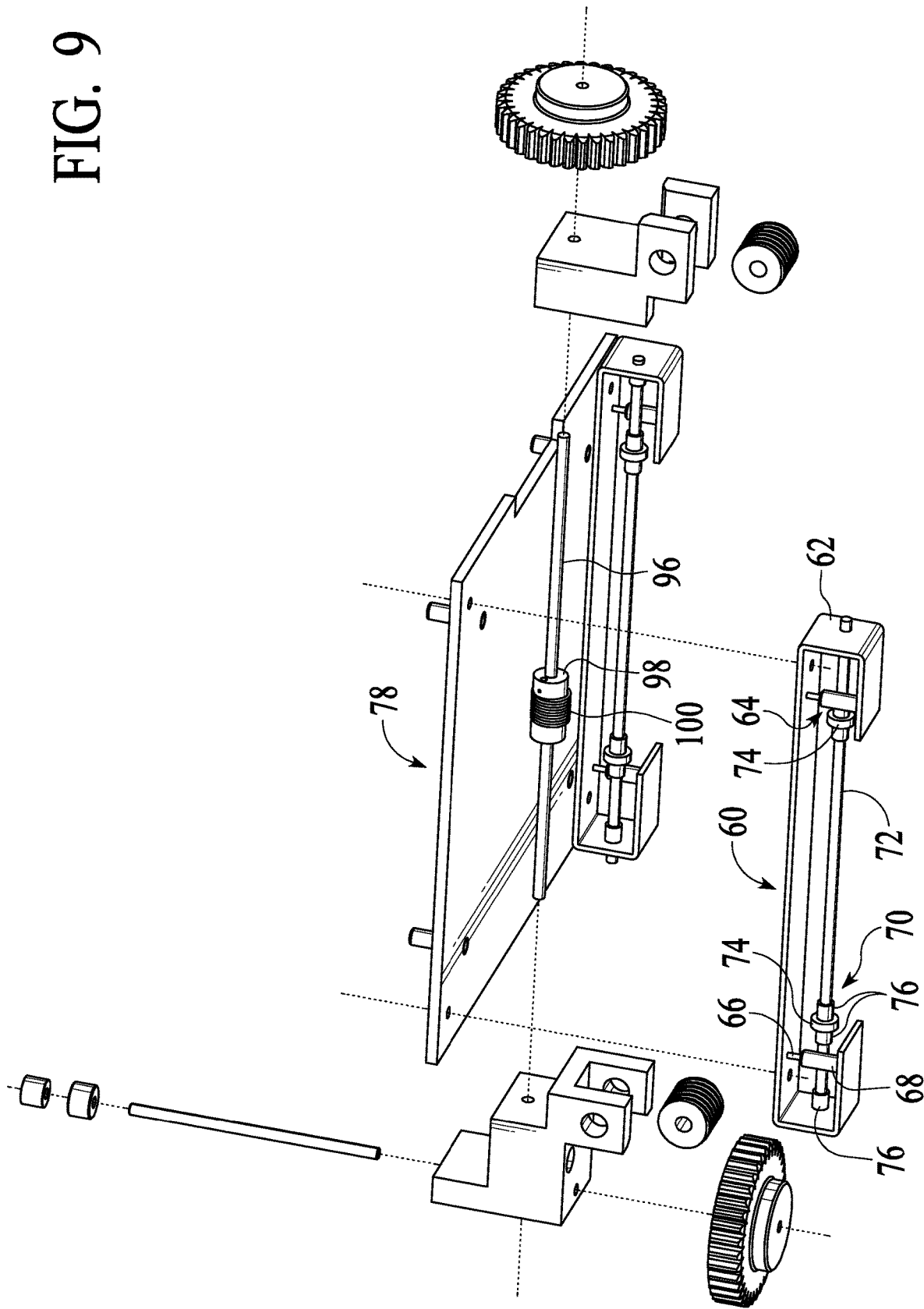

FIG. 8

FIG. 9



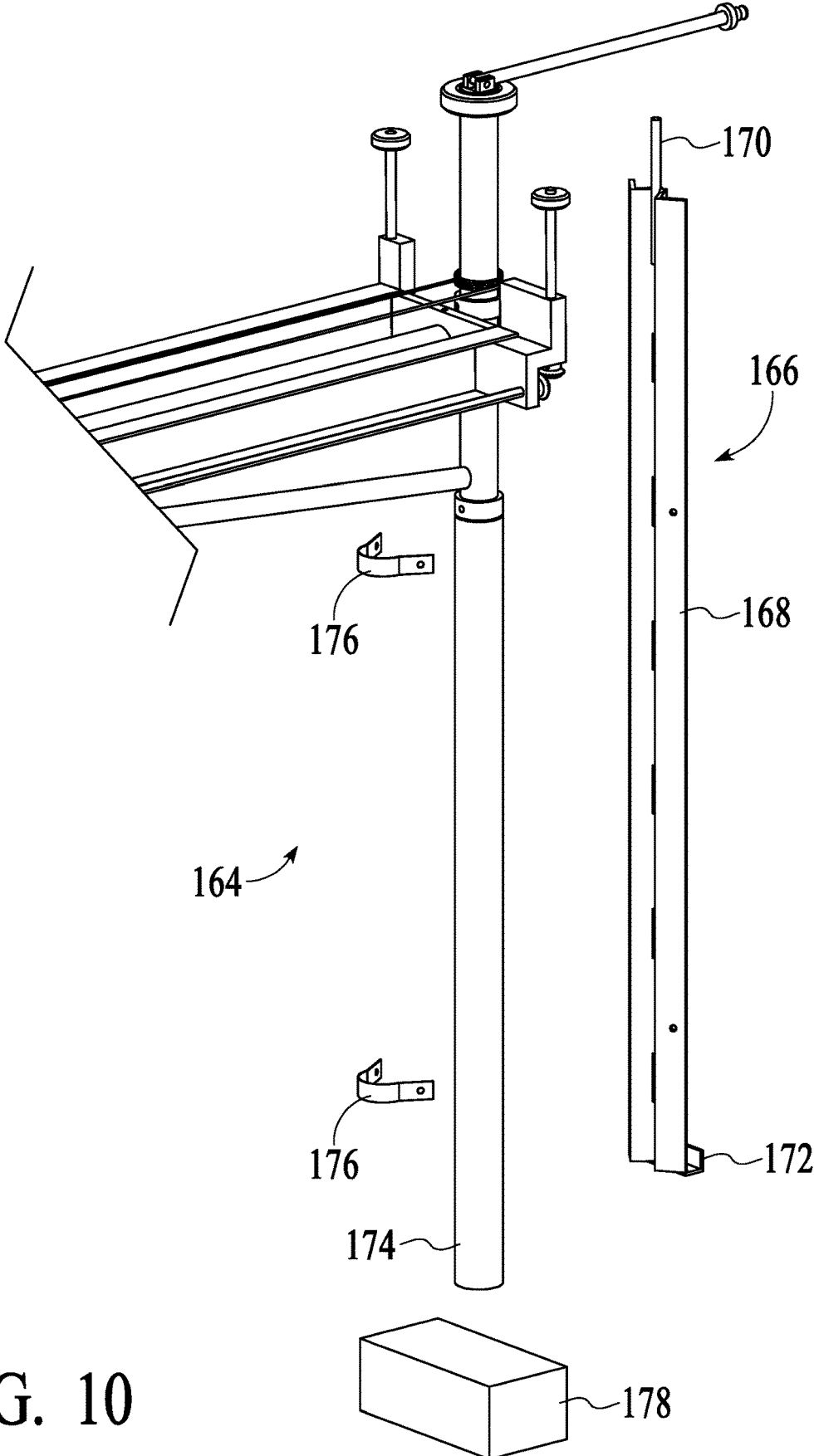

FIG. 10

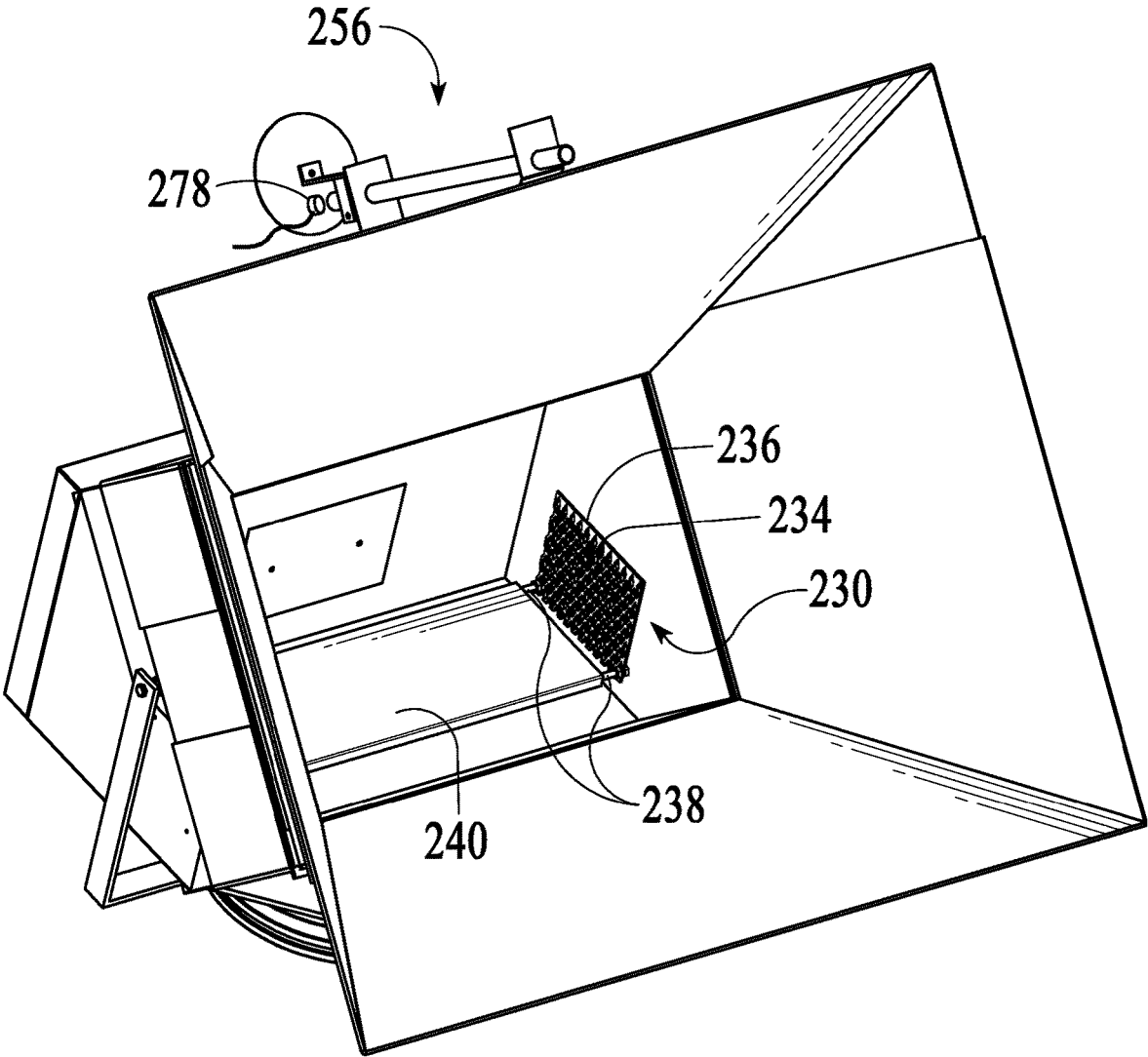

FIG. 11

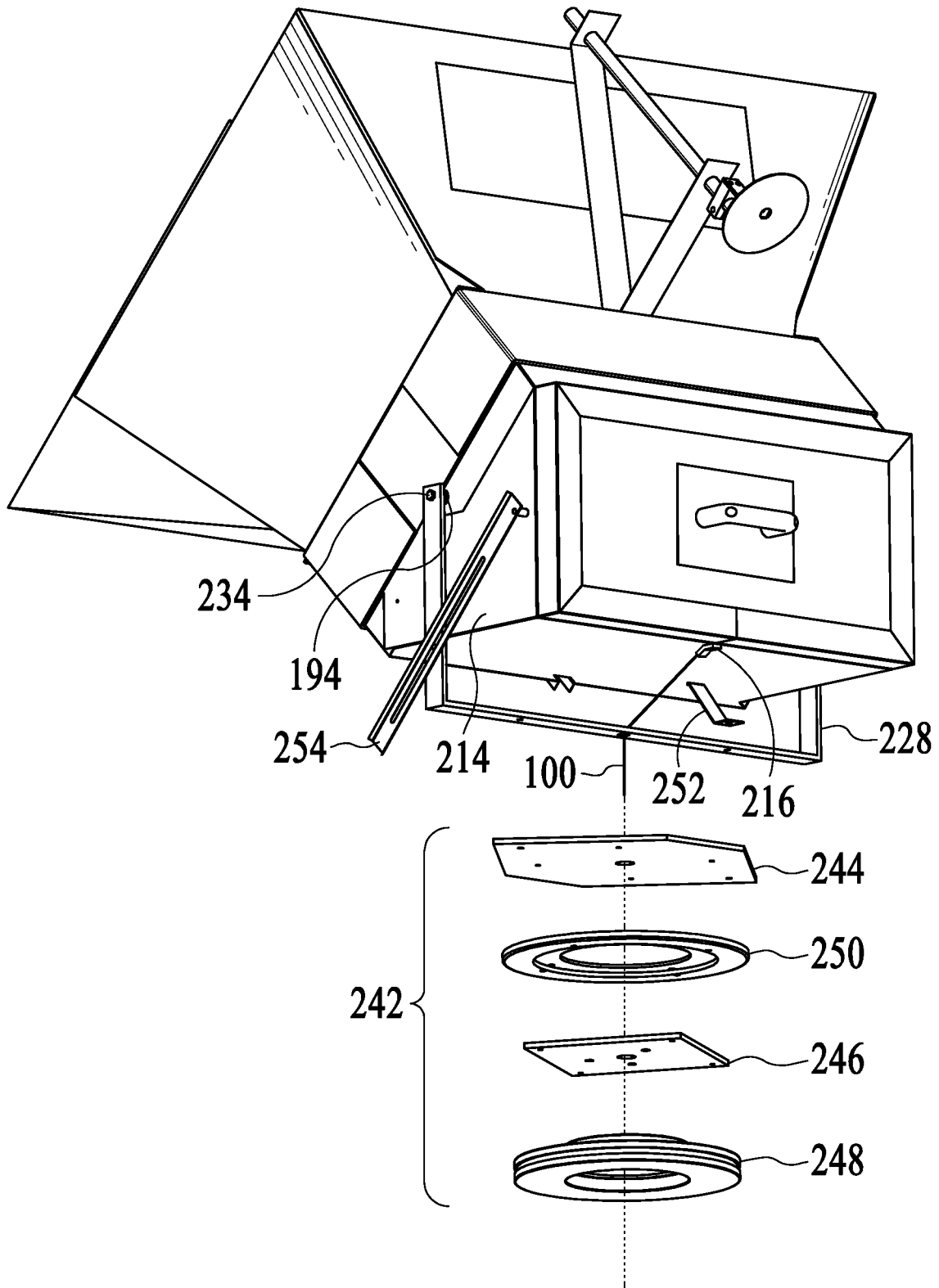

FIG. 12

FIG. 13

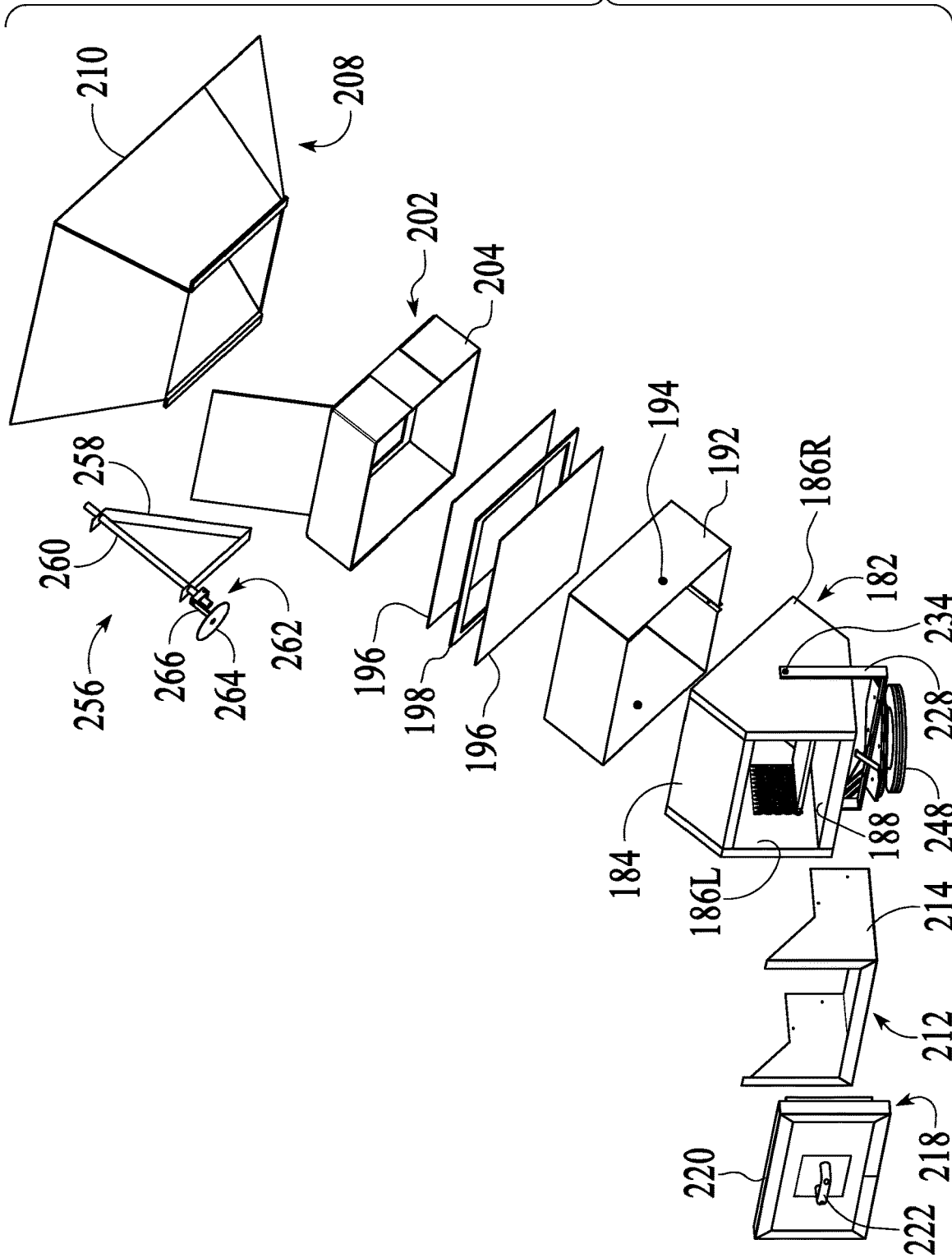
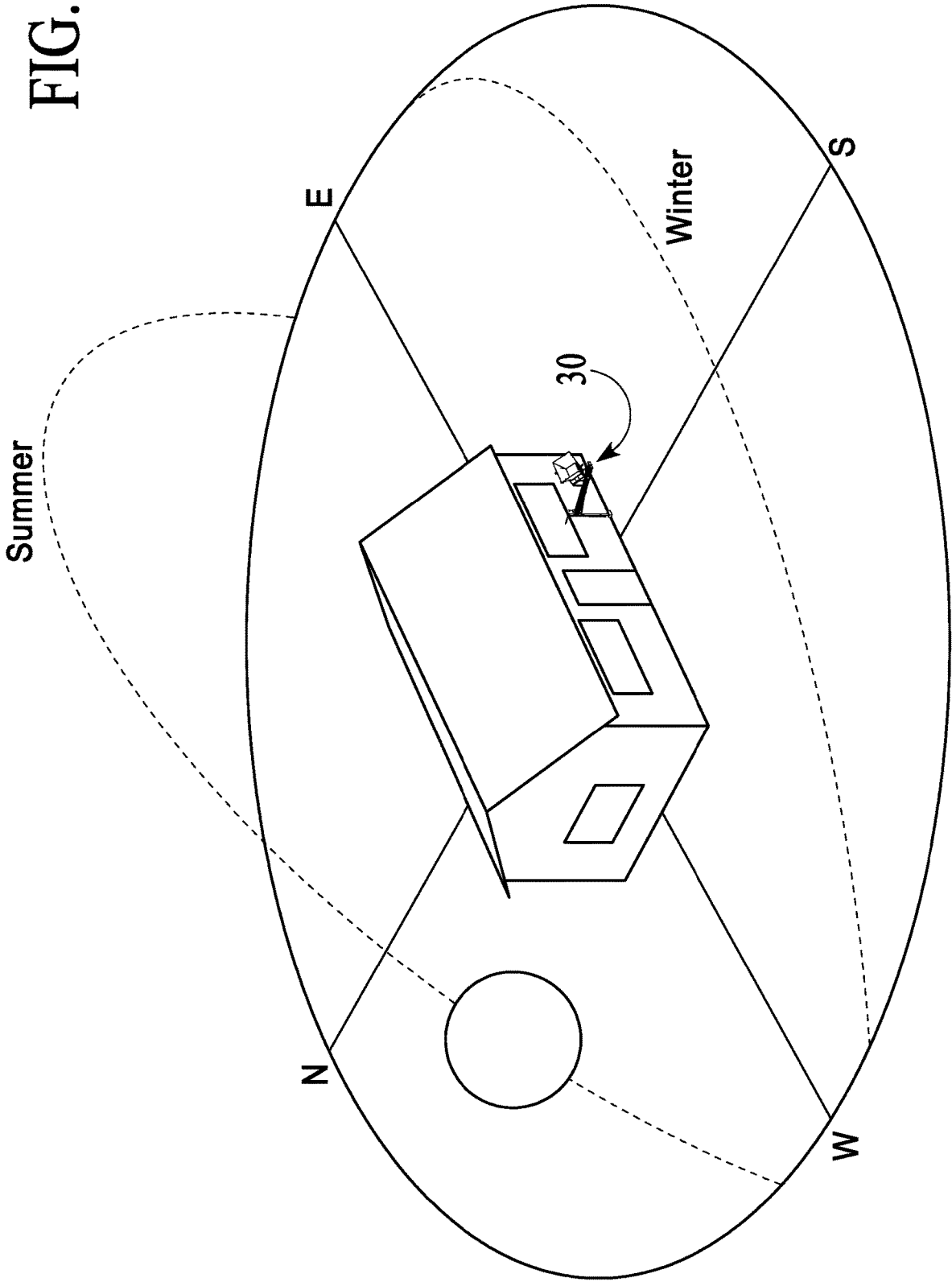

FIG. 14





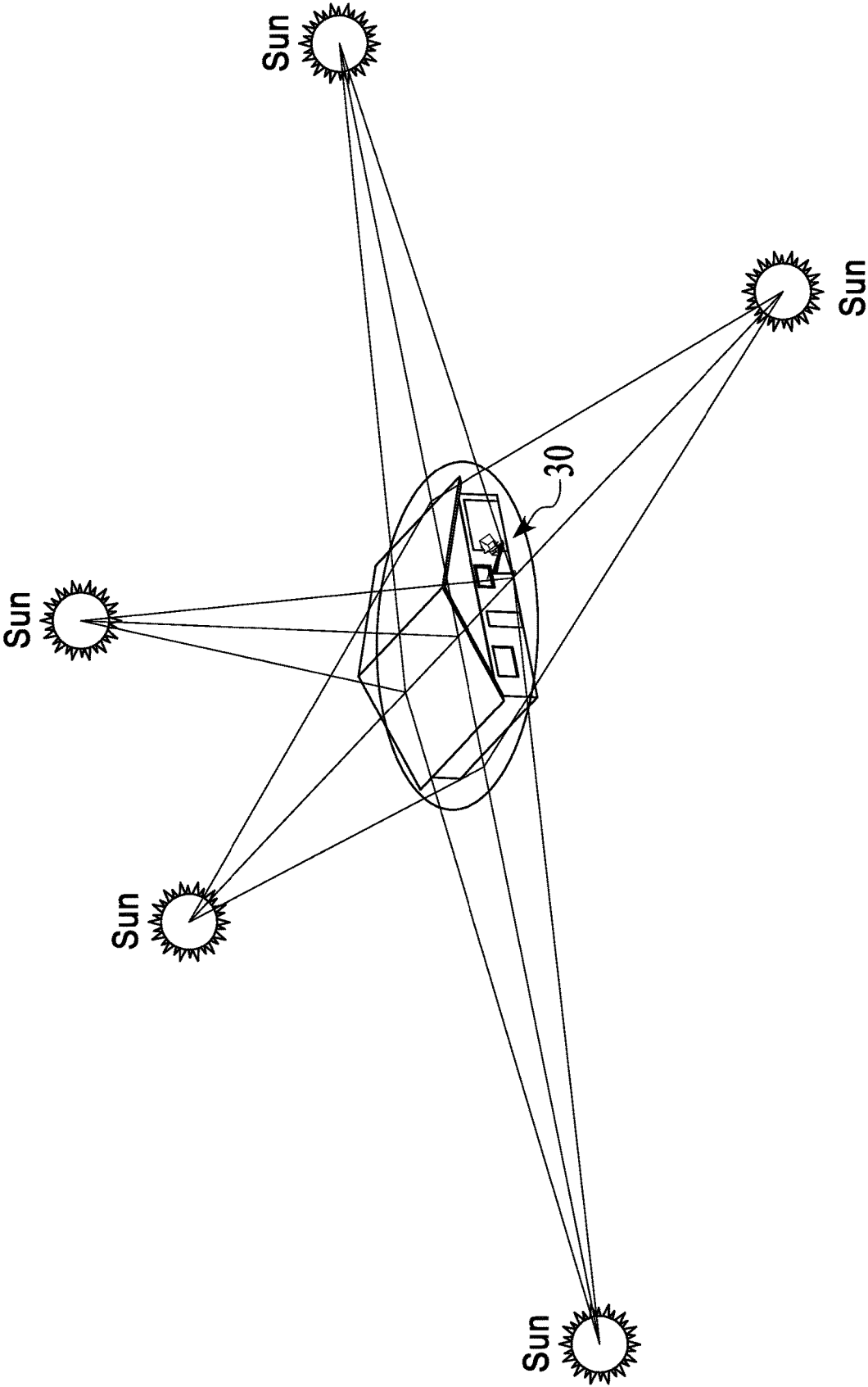

FIG. 15

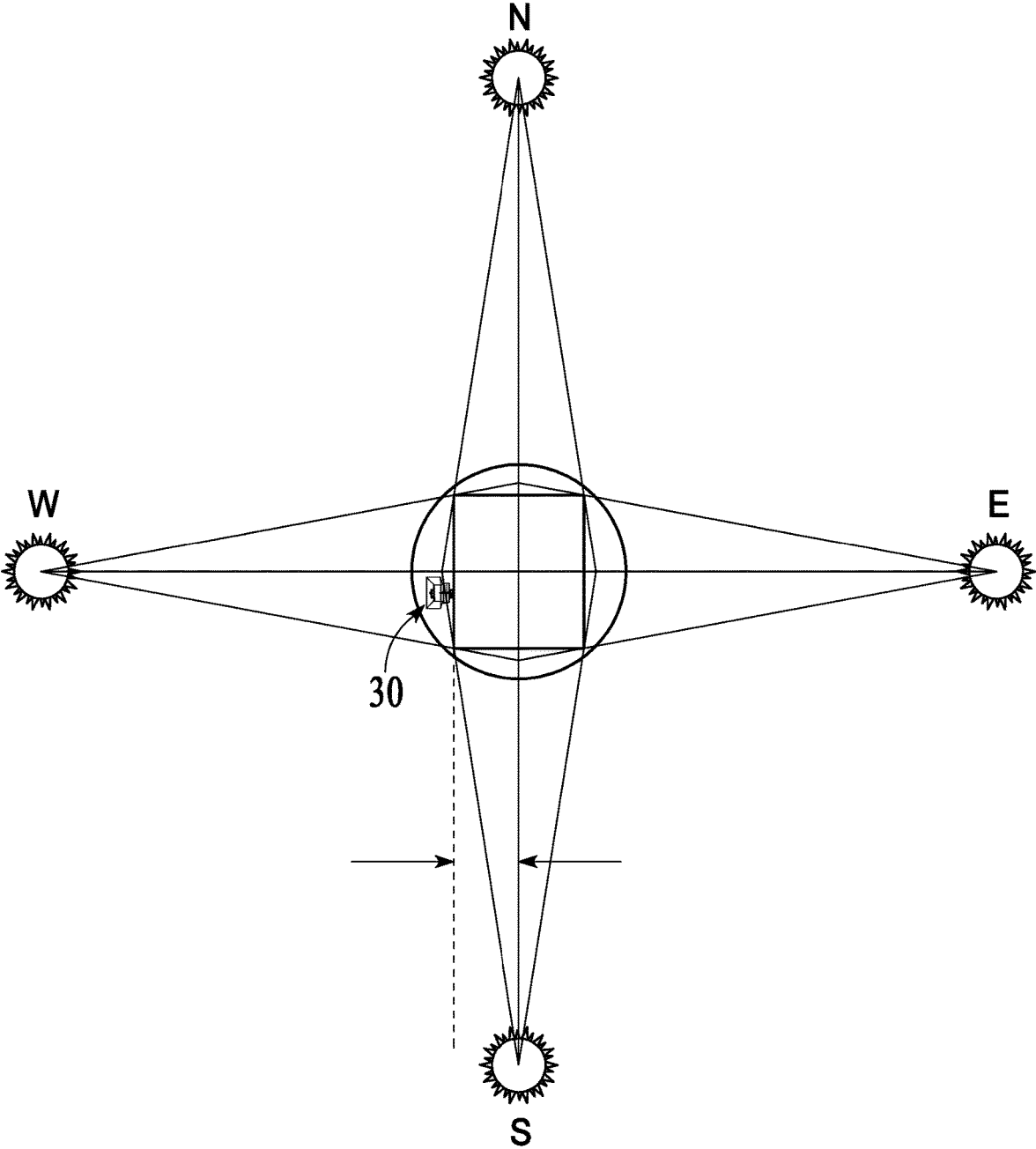

FIG. 16

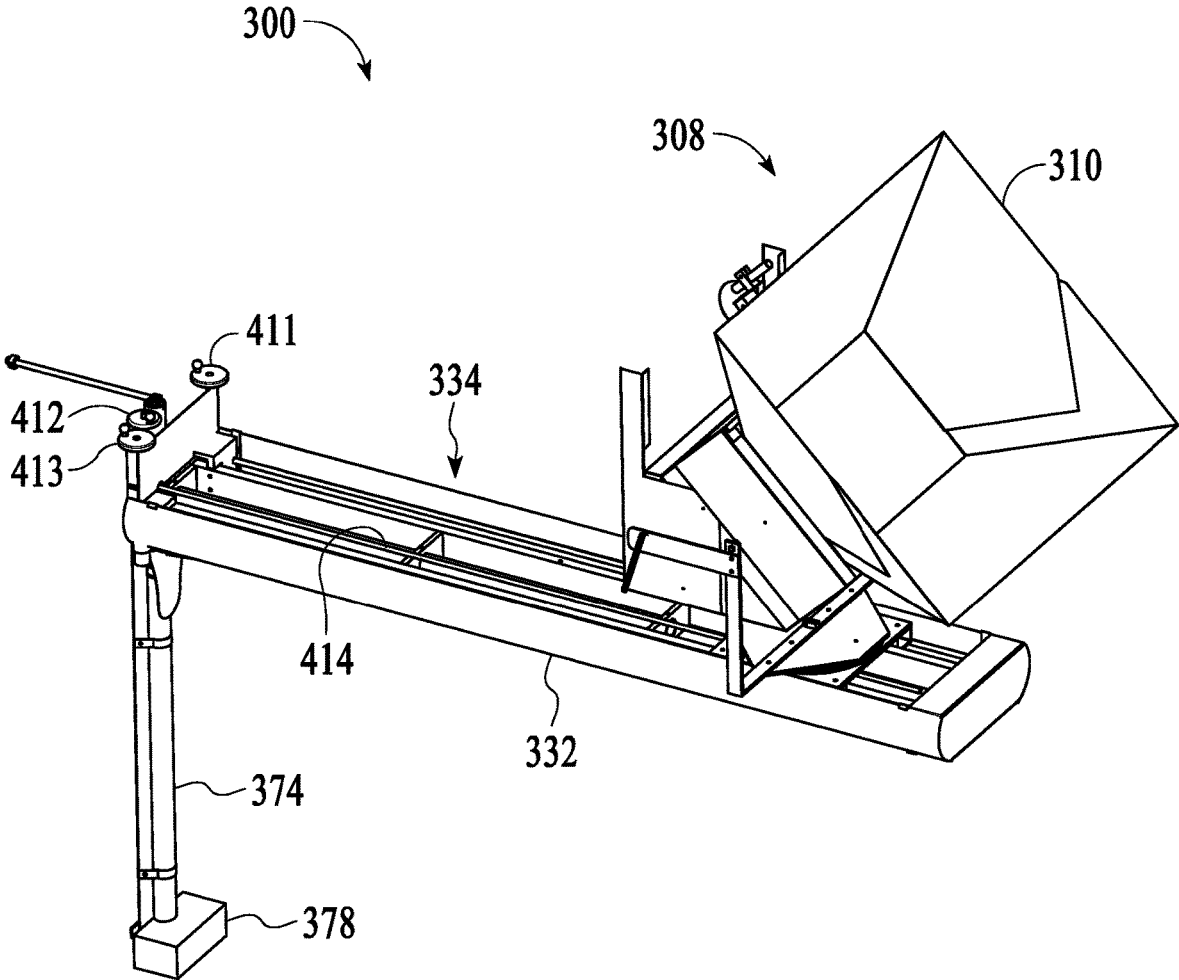

FIG. 17

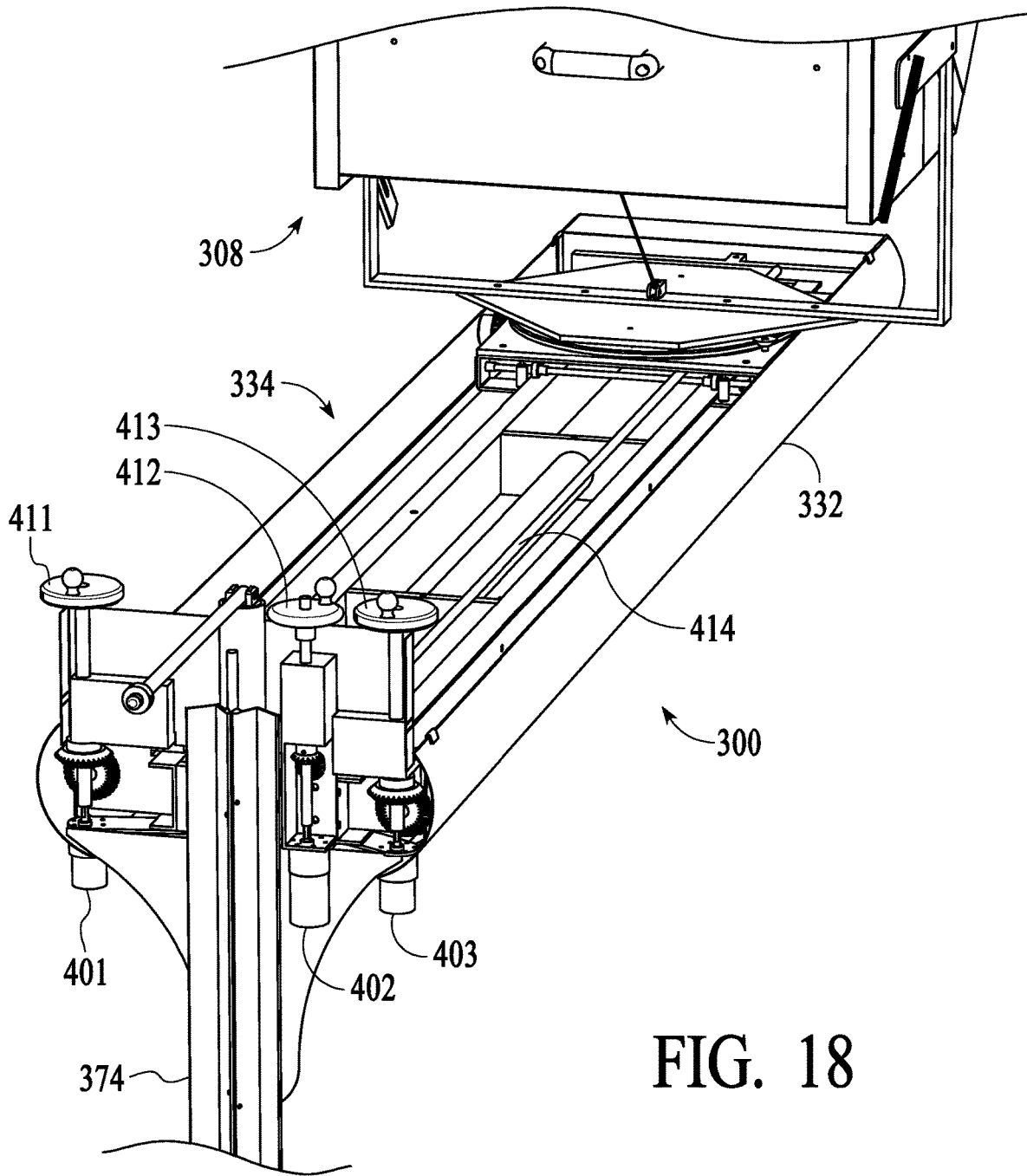

FIG. 18

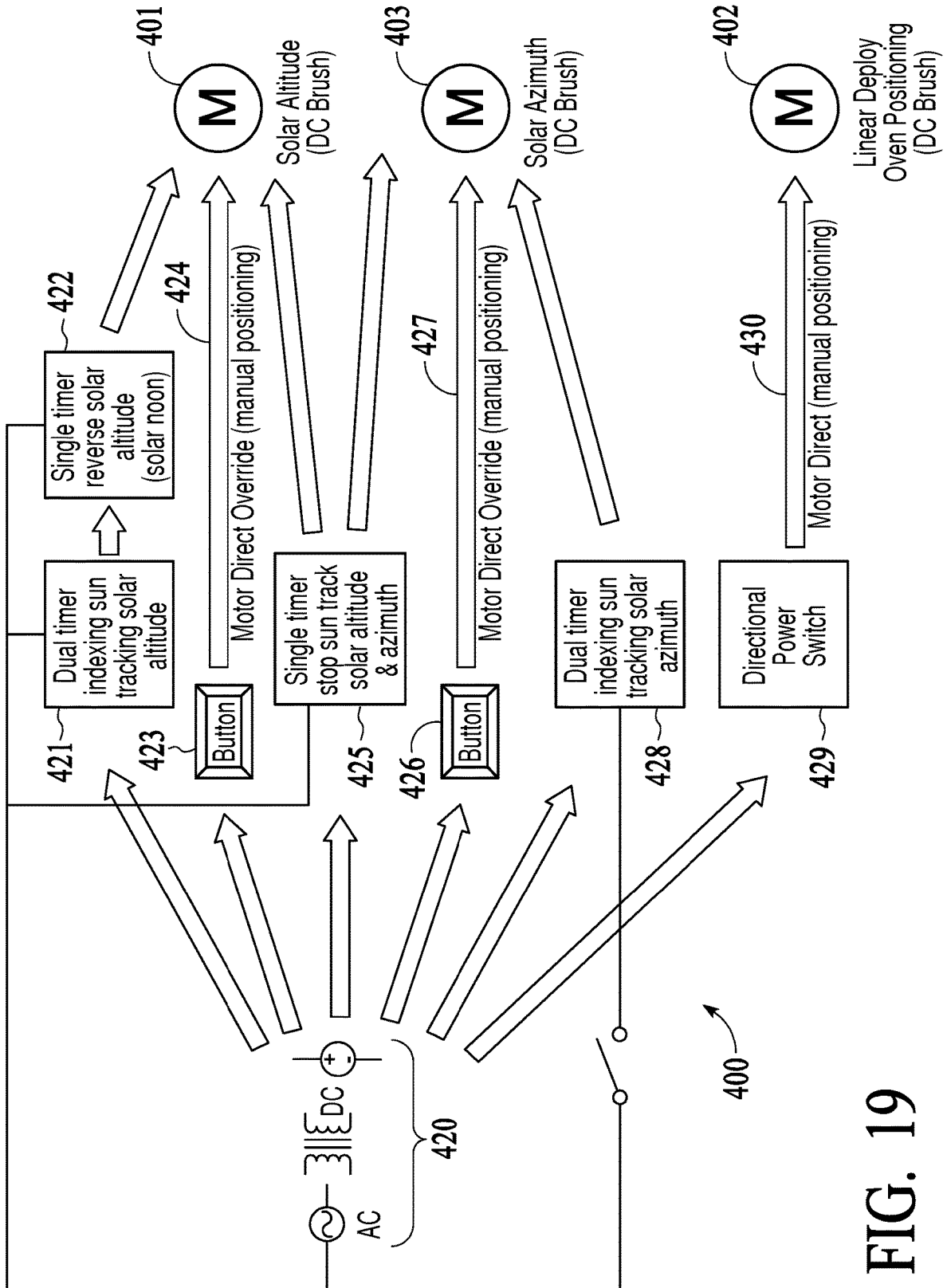

FIG. 19

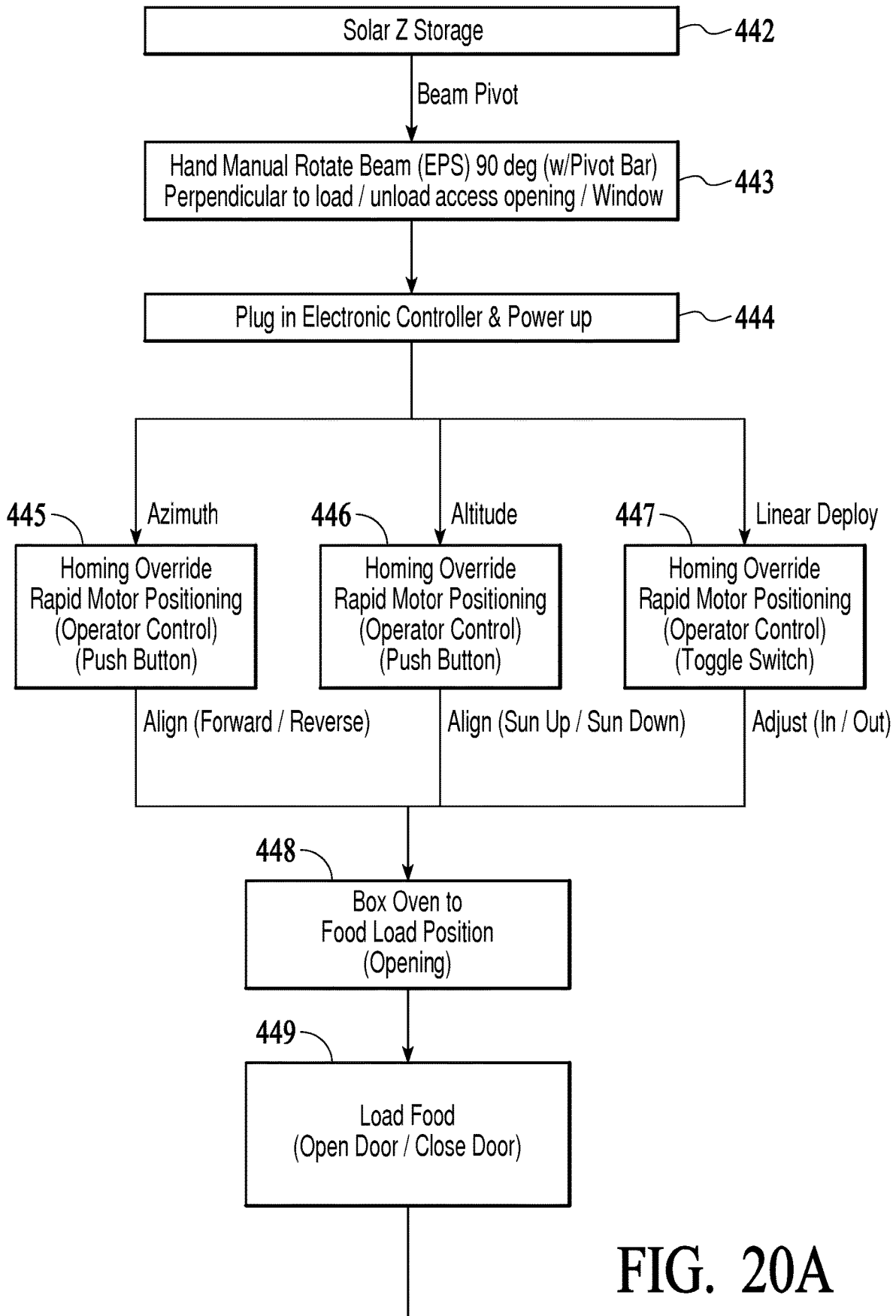

FIG. 20A

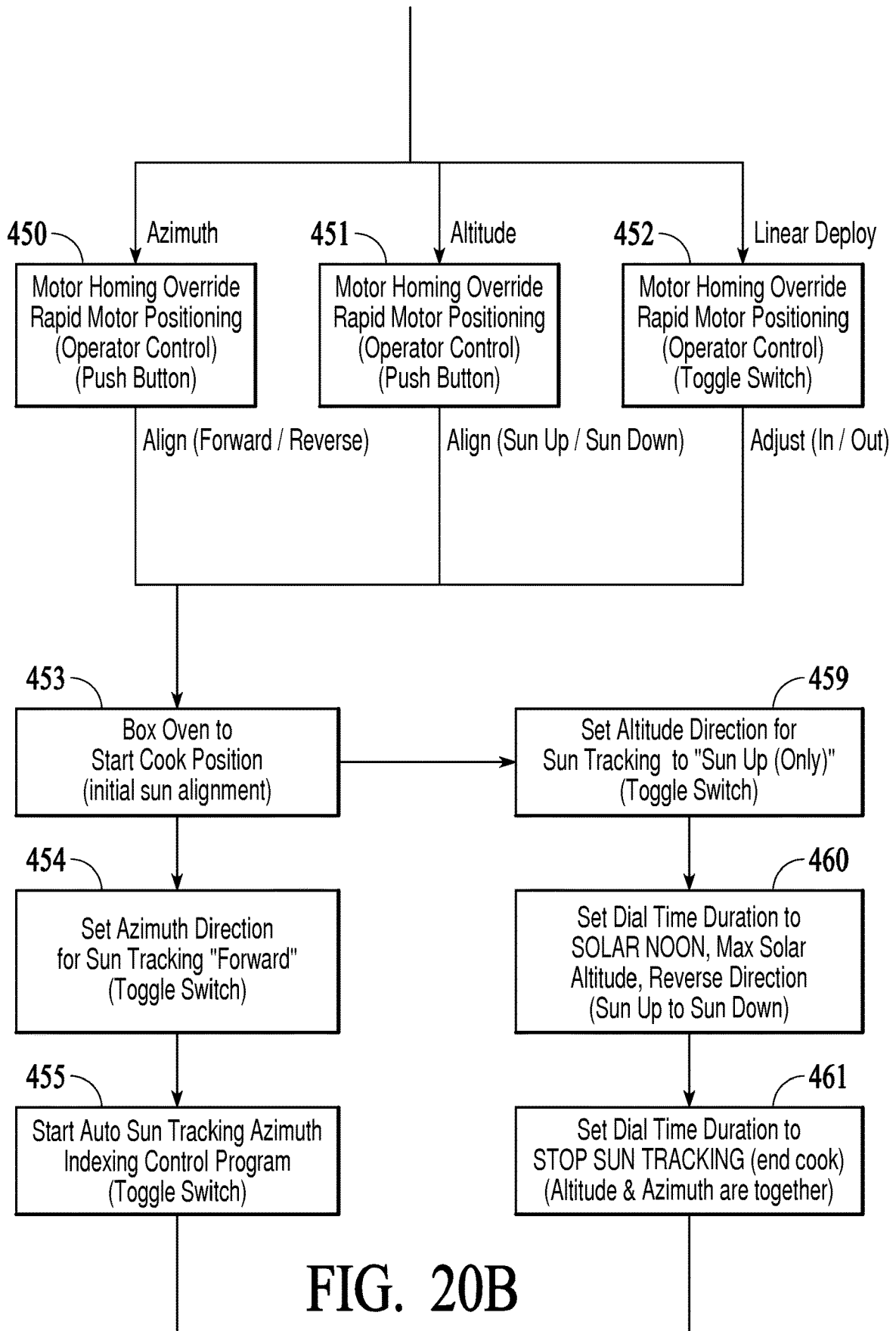

FIG. 20B

FIG. 20C

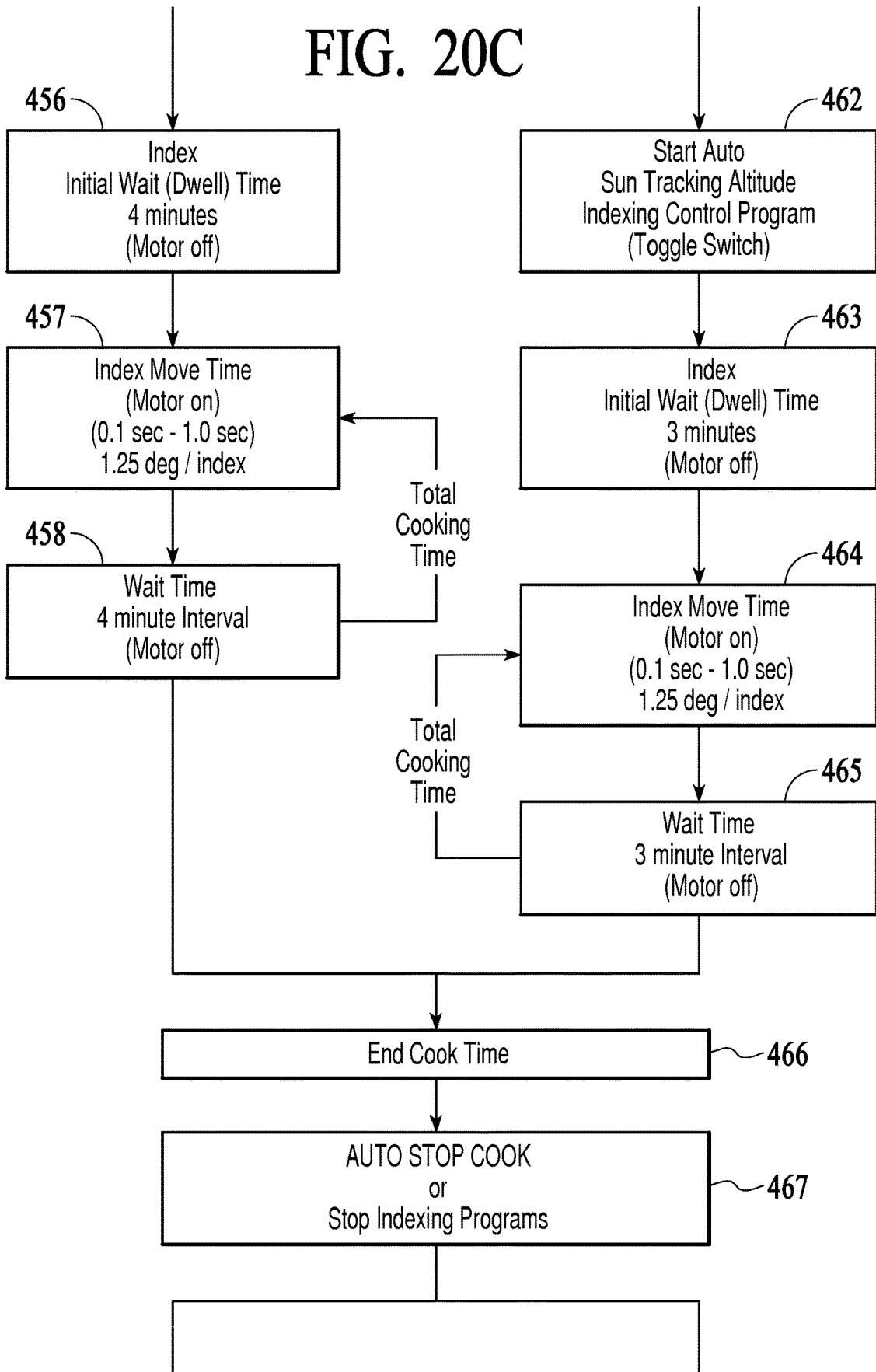
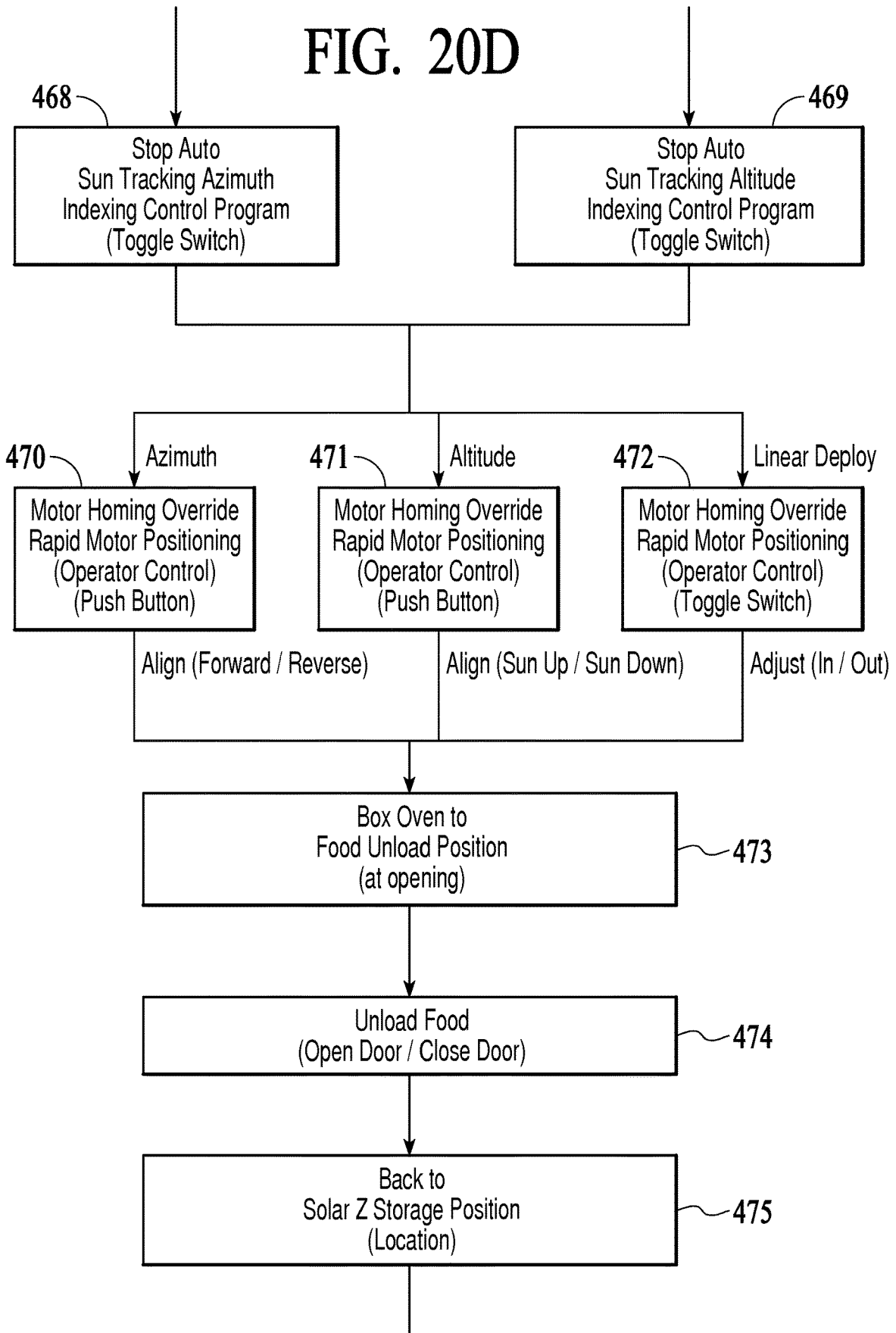



FIG. 20D



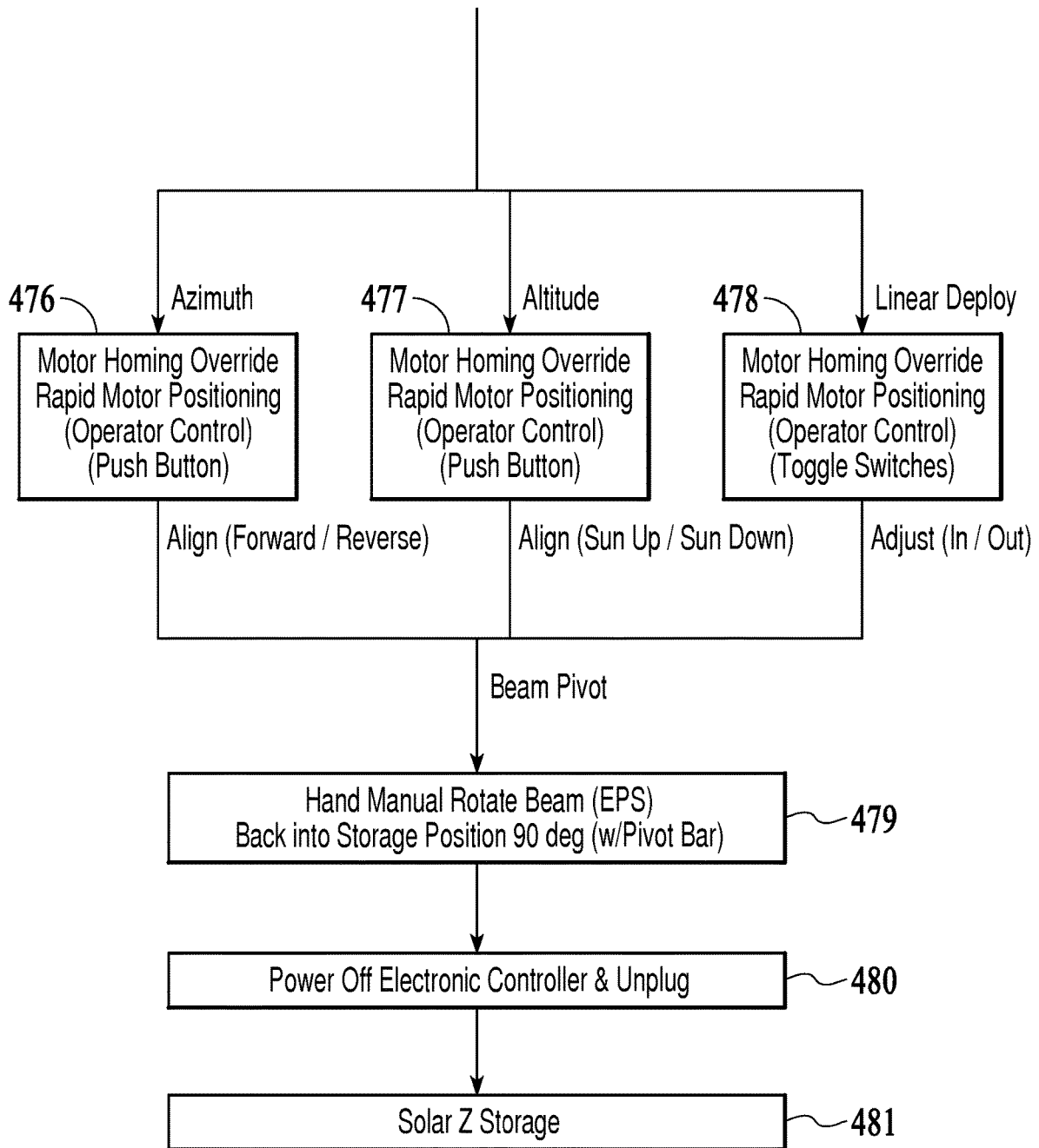

FIG. 20E

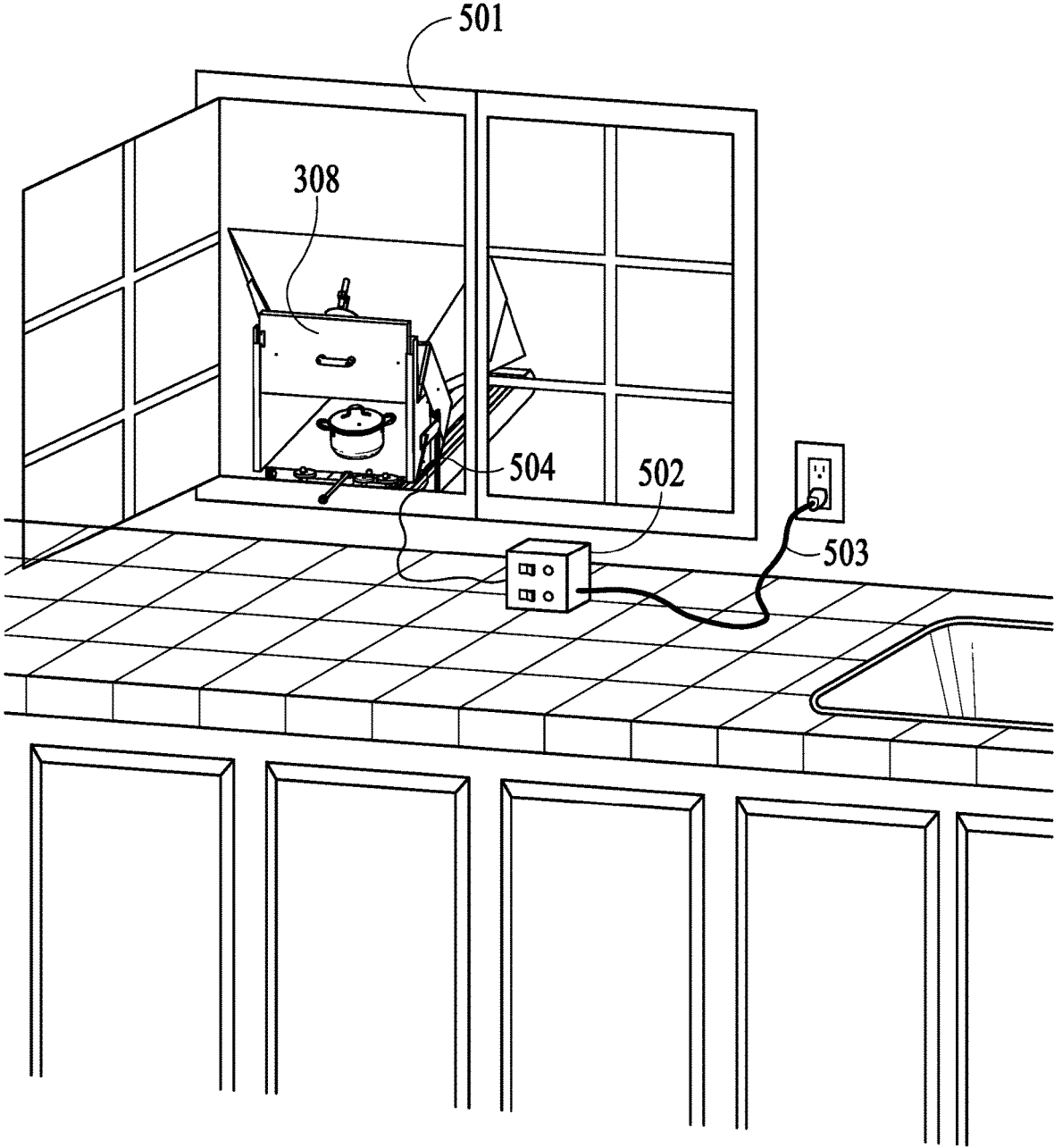
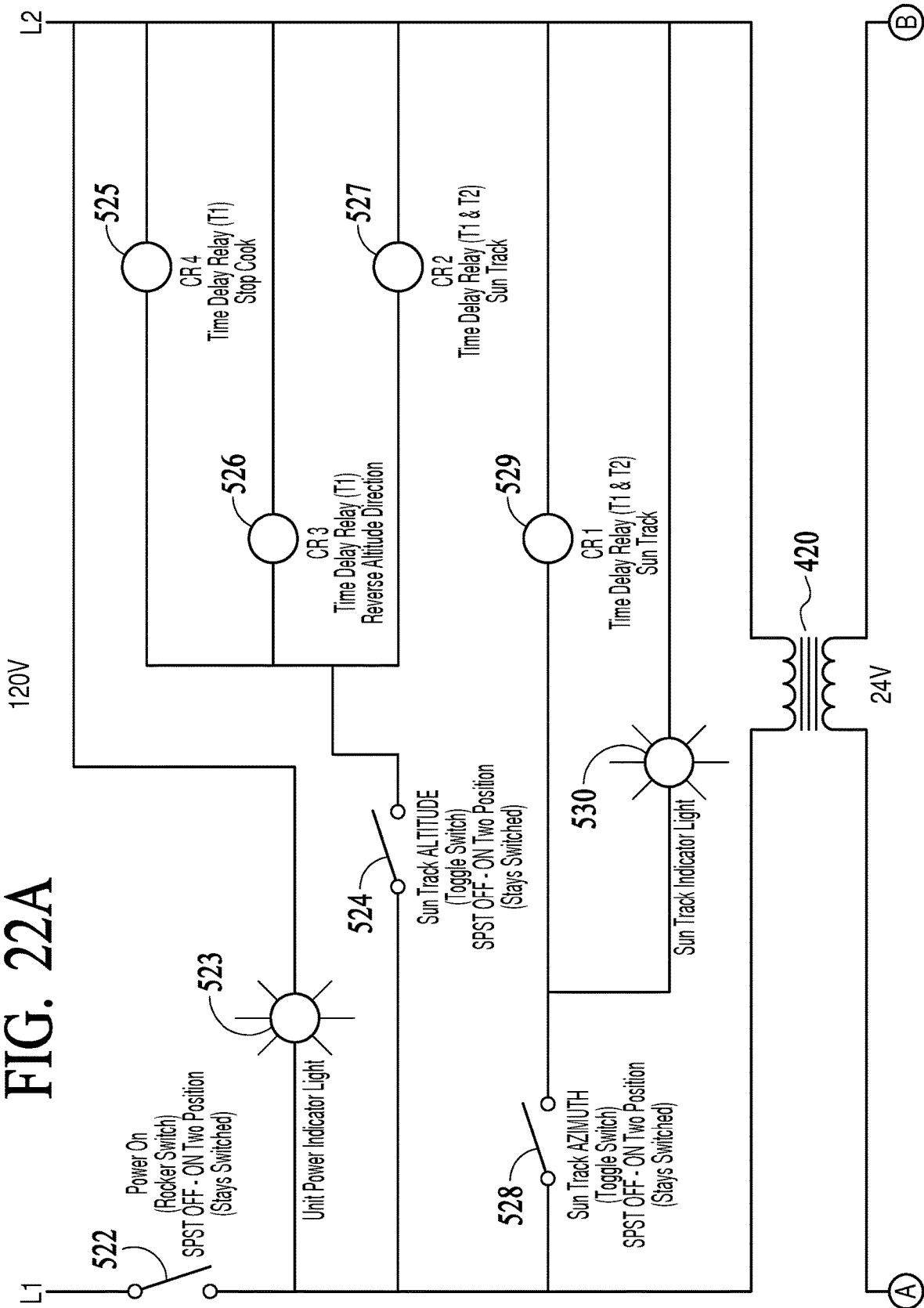

FIG. 21

FIG. 22A



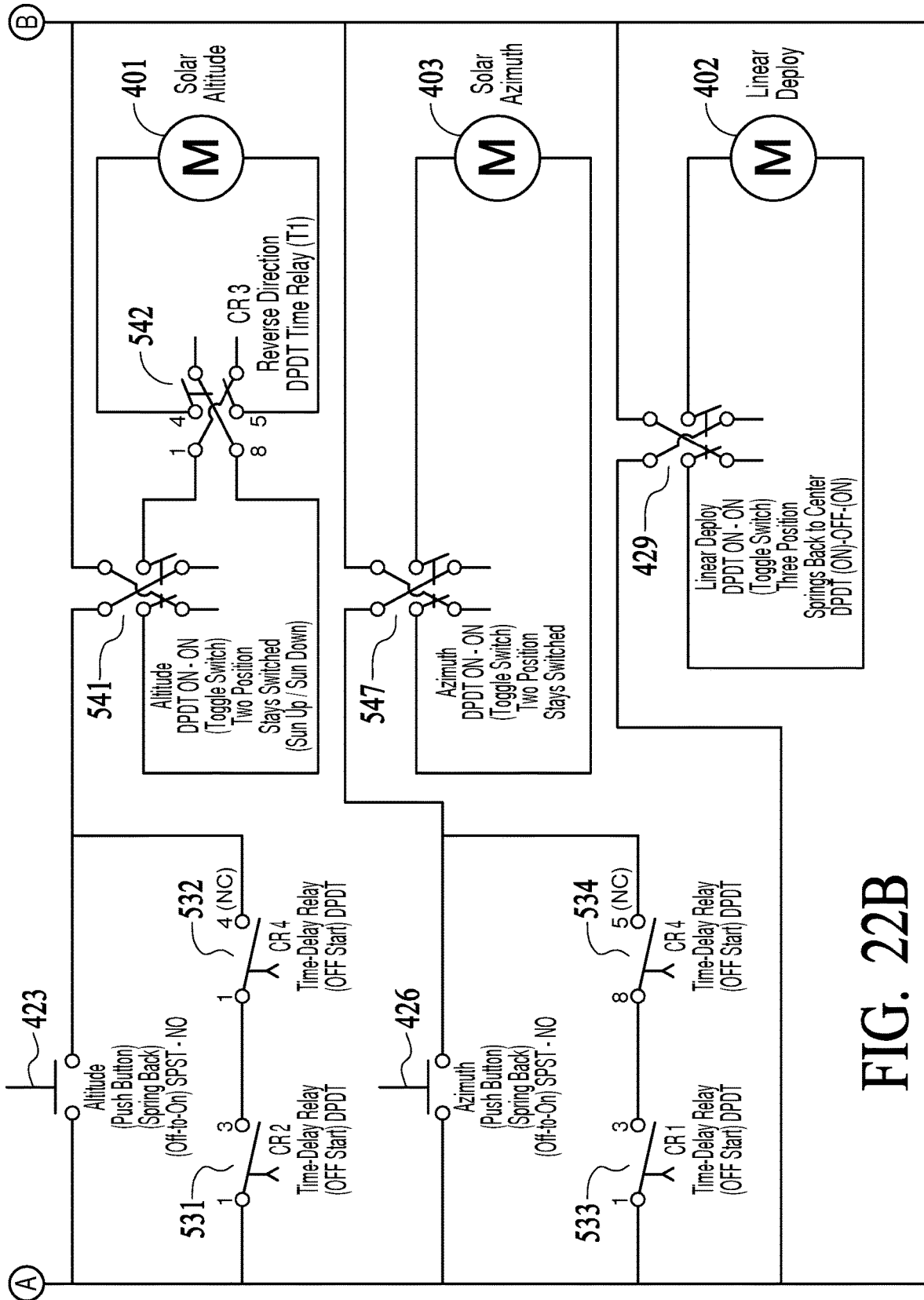
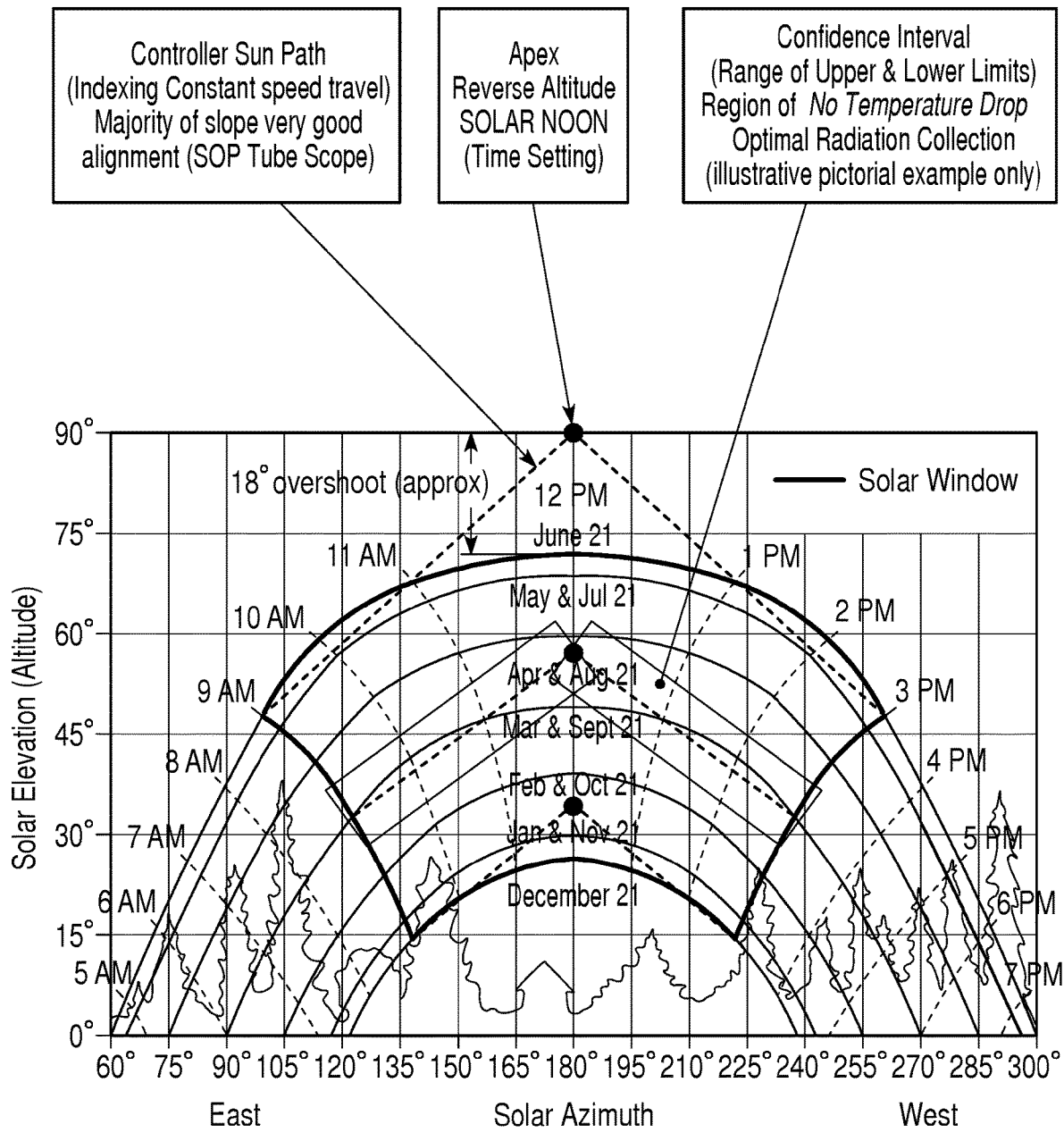

FIG. 22B



Sun Path Chart  
Lat: 38 ; Long -120  
(Solar) time zone: -8  
San Francisco

FIG. 23

Summary  
 Solar Noon Clock Times  
 Average for Month  
 Santa Cruz, CA Yr 2020 Table  
 (Calculated from Solar Noon Time Table)  
 Solar Noon (Solar Zenith Local Times, Santa Cruz, CA USA

SOLAR NOON		Range	Range		
Hrs Clock Time		Max	Min		
Mean Averages (12 Months)					
ST Avg	1210.8 1207	1221	1153	28	Minutes
DST Avg	1306.6 1304	1315	1253	22	Minutes

Notes:

All data of each day for 12 months from Solar Noon clock time data sheet

ST = Standard Time

DST = Daylight Savings Time

\* = Actual Clock Time Month Average

\*\* = Calculation Conversion Time

7 Days March split between ST & DST accounts for difference in average in approximation calculations (two different ways)

Solar Noon Clock Time

Month	Time Change	Hrs (Avg)	Range (MIN - MAX)		Direction (Chronological Time)	Sun Rise Earliest	Sun Set Latest	Day Light Span (Approx. Hrs)	
Jan	ST	1217	1211	1221	Min to Max	711	1731	10.5	Jan
Feb	ST	1221	1220	1222	Min to Max	639	1802	11.5	Feb
Mar	ST	1219	1220	1218	Max to Min (7 days)	629	1808	11.5	Mar
Mar	DST	1315	1318	1312	Max to Min (22 Days)	654	1930	12.5	Mar
Apr	DST	1307	1311	1305	Max to Min	614	1956	14	Apr
May	DST	1304	1305	1305	Max to Min	550	2021	15	May
Jun	DST	1308	1306	1311	Min to Max	548	2031	14.5	Jun
Jul	DST	1313	1312	1314	Min to Max	552	2031	14.5	Jul
Aug	DST	1311	1314	1308	Max to Min	613	2014	14	Aug
Sep	DST	1302	1307	1257	Max to Min	639	1935	13	Sep
Oct	*1253 DST	1293	1257	1251	Max to Min	703	1841	14.5	Oct
Nov	*1153 ST	1193	1151	1157	Min to Max	632	1710	10.5	Nov
Dec	ST	1204	1157	1211	Min to Max	703	1701	10	Dec

FIG. 24

**SOLAR OVEN POSITIONING**

BACKGROUND

A solar oven uses the energy of direct sunlight to heat food or drink. Solar cooking is a form of outdoor cooking and is often used where it is desired to minimize fuel consumption. Use of solar ovens helps reduce fuel costs and air pollution. It can also help to slow down deforestation and desertification where the alternative is to use gathered firewood for cooking.

A solar oven produces heat by concentrating sunlight and converting the light to infrared heat. Typically, a reflective mirror of polished glass, metal metalized film concentrates light that then is used to produce heat from the sun. The heat is contained in a small cooking area. A solar oven makes efficient heat by the conversion of light to heat. This is done, for example, by using a black or other low reflectivity surface on cooking containers to create heat that is added and trapped in the cooking area.

The solar oven is positioned towards the sun in order to maximize heat generation. As the sun travels across the sky, the position of the solar oven can be adjusted to optimize position with respect to the sun and to avoid shadows. When the solar oven is to be used for several hours untended, the solar oven can be turned to face the zenith of the sun's path so as to optimize captured radiation during the day.

BRIEF DESCRIPTION OF THE DRAWINGS

FIG. 1 is a perspective overall view of a solar oven system installed onto a building structure in accordance with an embodiment.

FIG. 2 is a front perspective view, from outside of a building, of a solar oven system installed on a building structure at a window opening in accordance with an embodiment.

FIG. 3 is a rear perspective view of the solar oven system in accordance with an embodiment.

FIG. 4 is a perspective view of an extended positioning system in accordance with an embodiment.

FIG. 5 is an exploded partial view of remote control elements and other extended positioning system features including a wall mount weldment.

FIG. 6 is an end view of an upper portion of an extended positioning system structural extension assembly showing a movable carriage connected to the structural extension assembly.

FIG. 7 is a front and top perspective view of a moveable carriage assembly.

FIG. 8 is a bottom perspective view of a moveable carriage assembly features.

FIG. 9 is a bottom exploded perspective view of a moveable carriage assembly and its features.

FIG. 10 is a partial exploded view of an extended positioning system showing a wall mount system.

FIG. 11 is a front perspective view without glaziers of a box solar oven assembly in accordance with an embodiment inside an oven area including a food rack and supports assembly.

FIG. 12 is a rear-view perspective of a box solar oven assembly with an azimuth bearing and pedestal base assembly exploded in this view in accordance with an embodiment.

FIG. 13 is a partial exploded view of a box solar oven assembly side view without exploding an azimuth bearing and pedestal base assembly.

FIG. 14 is a pictorial sketch showing a sun path with respect to a solar oven mounted in position onto a building structure.

FIG. 15 is a pictorial sketch showing a potential reach for solar energy retrieval of solar energy around corners and past roof eaves.

FIG. 16 is a top view sketch showing a potential reach for solar energy retrieval around corners and past roof eaves increasing exposure times with multiple direction installation.

FIG. 17 and FIG. 18 show a solar oven system with an electronic control unit.

FIG. 19 is a simplified block diagram of a control system.

FIG. 20A, FIG. 20B, FIG. 20C, FIG. 20D and FIG. 20E show a simplified flowchart showing cooking processing steps.

FIG. 21 shows a box solar oven assembly in position for loading and unloading food.

FIG. 22A and FIG. 22B show a simplified circuit drawing for a control system.

FIG. 23 is an example of a sun path chart.

FIG. 24 is an example of a chart used to identify solar noon.

LIST OF REFERENCE NUMERALS

- 30 Solar Oven System
- 32 Extended Positioning System
- 34 Structural Extension Assembly
- 36 U-shaped Channel Rail Members (36R & 36 L)
- 38 Cross Members
- 40 Pivot Weldment
- 42 Vertical Pivoting Member
- 44 Horizontal Beam Supporting Member
- 46 Welded Stud
- 48 Beam Suspension Support Truss Assembly
- 50 Brace Bar
- 52 Brace Bar Attachment Bracket
- 54 Weldment Pivot Bearing Collar
- 56 Cable Drive Spool Collar
- 58 Moveable Carriage
- 60 Rollers & Carriage Retaining Assembly
- 62 Roller Bracket
- 64 Lateral Shafts & Rollers Assembly
- 66 Lateral Roller Shaft
- 68 Lateral Roller
- 70 Vertical Load Shafts, Bearing Rollers, & Collars Assembly
- 72 Vertical Load Shaft
- 74 Vertical Load Bearing Roller
- 76 Vertical Load Shaft Collar
- 78 Base plate Assembly
- 80 Base Plate
- 82 Nesting pins
- 84 Solar Altitude Cable Winch Assembly
- 86 Solar Altitude Worm Gear Drive Mechanism
- 88 Solar Altitude Worm
- 90 Solar Altitude Worm Gear
- 92 Solar Altitude Worm Gear Housing
- 94 Cable Winch Drum & Shaft Assembly
- 96 Cable Winch Shaft
- 98 Cable Winch Drum
- 100 Cable Winch Cable
- 102 Azimuth Bearing Drive Roller Assembly
- 104 Azimuth Worm Gear Drive Mechanism
- 106 Azimuth Worm
- 108 Azimuth Worm Gear



## 3

**110** Azimuth Worm Gear Housing  
**112** Drive Roller & Drive Roller Shaft Assembly  
**114** Drive Roller Shaft  
**116** Drive Roller  
**118** Drive Roller Collar  
**120** Remote Control Mechanisms & Devices  
**122** Linear Hand Wheel  
**124** Cable Drive Spool  
**126** Cable Loop Pulley  
**128** Cable Loop Pulley Mount Plate Bracket  
**130** Carriage Drive Cable  
**132** Azimuth Hand Wheel & Hand Wheel Drive Shaft Assembly  
**134** Azimuth Hand Wheel  
**136** Azimuth Hand Wheel Drive Shaft  
**138** Azimuth Miter Gear Drive Shaft Bracket  
**140** Azimuth Miter Gears  
**142** Azimuth "D" Profile Drive Shaft  
**144** Solar Altitude Hand Wheel & Hand Wheel Drive Shaft Assembly  
**146** Solar Altitude Hand Wheel  
**148** Solar Altitude Hand Wheel Drive Shaft  
**150** Solar Altitude Miter Gear Drive Shaft Bracket  
**152** Solar Altitude Miter Gears  
**154** Solar Altitude "D" Profile Drive Shaft  
**156** Extendable Lever Handle  
**158** Access Knob Positioning Collar  
**160** Sliding Drive Block Pivot Yoke  
**162** Wrench drive plug  
**164** Wall Mount System  
**166** Pivot Post Saddle Weldment  
**168** "M" Shape Saddle  
**170** Saddle Top Retaining Stud  
**172** Saddle Bottom Retaining Bracket  
**174** Pivot Post  
**176** Pivot Post straps  
**178** Ground Foundation Block  
**180** Box Solar Oven Assembly  
**182** Insulated Foam Box  
**184** Foam Box Top  
**186** Foam Box Sides (**186R** & **186L**)  
**188** Foam Box Bottom  
**192** Hoop Strap  
**194** Flange Bearings  
**196** Glazier  
**198** Glazier Spacer Frame  
**200** Glaser "L" Bracket Retaining Clips  
**202** Solar Collector Panel Mount Retainer & Insulating Enclosure Frame Assembly  
**204** Solar Collector Panel Mount Retainer & Insulating Enclosure Frame  
**208** Solar Collector Panels Assembly  
**210** Solar Collector panels  
**212** Cover Protector Assembly  
**214** Cover Protector  
**216** Solar Altitude Cable Attach Bracket  
**218** Door Assembly  
**220** Door  
**222** Door Handle  
**228** Yoke Member  
**230** Food Rack & Supports Assembly  
**234** Horizontal Pivot Bearing Bolt  
**236** Food Rack Side Plates  
**238** Food Rack Cross Rods  
**240** Food Rack Horizontal Plate  
**242** Azimuth Bearing & Pedestal Base Assembly

## 4

**244** Azimuth 12 Inch Bearing Top Mount Plate  
**246** Azimuth 12 Inch Bearing Bottom Mount Plate  
**248** Pedestal Base  
**250** Azimuth 12 Inch Bearing  
**252** Center of Gravity Biased Spring  
**254** Solar Altitude Locking Bar  
**256** Light Alignment Indicator Assembly  
**258** Tube Scope Box mounting bracket  
**260** Light Indicator Tube  
**262** Translucent Light Target Assembly  
**264** Translucent Target  
**266** Target Mounting bracket  
**268** Protective storage shelter cover  
**270** Azimuth Servomotor  
**272** Azimuth Servomotor Mount Bracket  
**274** Solar Altitude Servomotor  
**276** Solar Altitude Servomotor Mount Bracket  
**278** Feedback Light Sensor Unit  
**280** Azimuth Servo Drive Coupling  
**282** Solar Altitude Servo Drive Coupling  
**284** Solar Tracking Controller  
**300** Solar Oven System  
**308** Box Solar Oven Assembly  
**310** Solar Collector Panels Assembly  
**332** Extended Positioning System  
**334** Structural Extension Assembly  
**374** Pivot Post  
**378** Ground Foundation Block  
**400** Controller System  
**401** Solar Altitude Electric Motor  
**402** Linear Deploy Electric Motor  
**403** Solar Azimuth Electric Motor  
**411** Solar Altitude Override Handle  
**412** Linear Deploy Override Handle  
**413** Solar Azimuth Override Handle  
**414** Linear Deploy Lead Screw  
**420** Transformer  
**421** Timer  
**422** Timer  
**423** Override button Switch  
**424** Arrow  
**425** Timer  
**426** Override button Switch  
**427** Arrow  
**428** Timer  
**429** Directional Power Switch  
**430** Arrow  
**442-481** Logic Blocks  
**501** Kitchen Window  
**502** Casing  
**503** Power Cord  
**504** Connector Cable  
**522** Power Switch  
**523** Unit Power light  
**524** Switch  
**525** Time Delay relay  
**526** Time Delay relay  
**527** Time Delay relay  
**528** Switch  
**529** Time Delay relay  
**530** Sun Track indicator light  
**531** Time Delay relay Switch  
**532** Time Delay relay Switch  
**533** Time Delay relay Switch  
**534** Time Delay relay Switch  
**541** DPDT Toggle Switch  
**542** Cross wired relay Switch  
**547** DPDT Toggle Switch

## DETAILED DESCRIPTION

A solar oven system is installed on an outside wall of a building structure outside the cooking area and accessed through a window or other opening accessible from within the cooking area with the apparatus reaching out away from the building structure into the outside environment when operated. The solar oven system integrates all of the needed solutions of the various operation process steps and numerous problems related to the requirements of the entire solar cooking process into one complete seamless cohesive operation.

FIG. 1 and FIG. 2, of the solar oven system 30 shows a basic version of a solar oven system embodiment installed onto a building structure. A solar oven system 30 includes an extended positioning system 32 and a radiation collection device. For example, the radiation collection system is represented in FIGS. 1 and 2 by a box solar oven assembly 180. Box solar oven assembly 180 is used for converting solar energy into heat for cooking food or other solar processes. Positioning system 32 is used to deploy, and align box solar oven assembly 180.

The extended positioning system 32 is installed, mounted, or connected onto the wall by features in FIGS. 3, 4, 5, & 10 with a saddle top retaining stud 170, saddle bottom retaining bracket 172, and a ground foundation block 178. A wall mount system 164 includes a pivot post saddle weldment 166, of which includes an M-shape saddle 168 (FIG. 10) to nest a pivot post 174, saddle top retaining stud 170 for top attachment to the building structure, and a saddle bottom retaining bracket 172 for the bottom attachment to the building structure. The wall mount system 164 also includes a pivot post 174 for receiving a pivot weldment 40, two pivot post straps 176 to secure and adjust the pivot post into a pivot post saddle weldment 166, and a ground foundation block 178 to support the vertical component force loads of an embodiment itself and its process operation loads.

The saddle top retaining stud 170 is inserted into a hole located in the underside of the exterior lower horizontal window frame material or is already provided by the existing vertical grooves in the building siding material, (such as "T111 and other siding materials with vertical groove features) when the lower horizontal window frame material is mounted over the grooves which then provides a hole feature which can be used as the retaining hole to secure the upper portion of the wall mount system. The saddle bottom retaining bracket 172 slides behind and onto the lower edge of the building siding material between the vertical flange of the saddle bottom retaining bracket 172 and the M-shape saddle 168 mounting surface therefore retaining the lower portion of the wall mount onto the wall material. The M-shape saddle 168 is configured to provide the center portion of the design to protrude out beyond the outer edges or general surface plane of the wall mounting surface of the M-shape saddle 168 therefore providing insertion of the M-shape saddle 168 center material protruding into the siding vertical groove for preventing twisting after mounting and adding strength and retention of the system in any position after installation. The ground foundation block 178 supports the entire vertical component load force vector after adjusting and setting of the installation to the wall. This design removes (or prevents) the vertical load force component vector from the installed pivot post saddle weldment 166 and keeps the wall mount system 164 from disengaging vertically downward. It does this by first redirecting all the vertical load force directly down onto the ground providing for a load path which provides no unnecessary vertical force

on wall mount weldment 166, therefore, not requiring additional fastening methods in order to retain the wall mount weldment 166 vertically onto the building structure. The pivot post straps 176, after installed and setup, only provide retaining of the pivot post 174 into the pivot post saddle weldment 166 in the horizontal component force vector loading directions.

The wall mount system 164 is installed on to the wall by inserting and sliding the pivot post saddle weldment 166 into the groove of the siding material and simultaneously sliding up and in both the saddle top retaining stud 170 along with the saddle bottom retaining bracket 172 simultaneously into their proper securing locations on the wall as previously described above. The pivot post 174 is then inserted into the "M" shape saddle 168 nesting feature as shown in FIG. 4 with the two pivot post straps 176 while loading a downward vertical force of the pivot post 174 onto the ground foundation block 178 before tightening the two pivot post straps 176 in place. As stated above, this design and setup prevents the vertical load force from siding out the upper and lower retaining features of the previously described pivot post saddle weldment 166. No fasteners are required to make the secure installation to the building wall because of this vertical load path design directing to the ground foundation block 178 first, which again, prevents sliding out of the weldment 166 retaining features.

Extended positioning system 32 in FIGS. 2, 4, and 5 includes a structural extension assembly 34 that provides linear extension and manipulation of the box solar oven assembly 180 out away from the building structure. The structural extension 34 includes two U-shape channel rail members 36R and 36L connected together by cross members 38 assembled by screws, welds or other standard structural attachment methods. Referring to FIG. 4, the cross members 38 have a hole in the center with set screws at the plate edge in order to receive and secure for attachment a horizontal beam supporting member 44 of a pivot weldment 40.

The pivot weldment 40 includes a vertical pivoting member 42 including a feature of a welded stud 46 for brace bar 50 attachment for structural support and a horizontal beam supporting member 44 which provides pivoting attachment of the structural extension 34 to the wall mount system 164. Set screws provided in the structural extension 34 cross members 38 are used to secure to the horizontal beam supporting member 44. A lower portion of the vertical pivoting member 42 of the pivot weldment 40 is then slip fit into the top of the pivot post 174 in FIGS. 2 and 4 to allow pivoting (angular rotation) of the structural extension 34 using an extendable lever handle 156 by the operator. A beam suspension support truss assembly 48, made up of the brace bar 50 and a brace bar attachment bracket 52 attached with screws or other methods to the structural extension 34 provides structural strength required to significantly extend and support operational load weights during operations.

Referring to FIGS. 4, 6, and 9, a moveable carriage 58 slides or rolls along the structural extension assembly 34 in a linear movement on vertical load shafts, bearing rollers, and collars assembly 70 to carry (or roll) the box solar oven assembly 180 into optimum locations for operating an embodiment. The moveable carriage 58 is attached to the structural extension assembly 34 by four lateral shafts and rollers assemblies 64 in FIGS. 6 and 9, which keeps the moveable carriage aligned and trapped to prevent any side derailment. Moveable carriage 58 also has two roller brackets 62 with material extending under the U-shaped channel

members **36R** and **36L** flanges in FIG. **6** for interference between channel members flanges and roller brackets **62** when a vertical ascending movement is applied. This prevents upward disengagement from the structural extension assembly **34**. These features keep the moveable carriage **58** from being lifted or removed from the structural extension assembly **34** while allowing only a longitudinal degree of freedom movement (linear) of the moveable carriage **58** along the length of the structural extension assembly **34**. Further, the moveable carriage **58** is prevented from rolling or sliding off the end of the structural extension assembly **34** by a cable loop pulley mount plate bracket **128**, therefore securely trapping the moveable carriage **58** (during assembly) onto the structural extension **34** while in operation.

The moveable carriage **58** in FIGS. **4**, **6**, **7**, **8**, and **9** includes a base plate assembly **78** made up of a structural base plate **80** with nesting pins **82** threaded (with machine nuts) or other methods of securing, positioning, and attaching a pedestal base **248** (FIG. **12**) of the box solar oven assembly **180** onto the extended positioning system **32** in FIG. **2**. Two rollers and carriage retaining assemblies **60** attach to the underside of base plate **80** with screws or a like standard attachment to create the carriage movement mechanism. It provides vertical load shafts **72**, and vertical load bearing rollers **74**, with rubber press fit retaining vertical load shaft collars **76**, for moving or driving the carriage along the structural extension assembly **34**. Carriage retaining assembly **60** provides for lateral control using lateral shafts and rollers assembly **64** with lateral roller shaft **66** and lateral rollers **68** guiding the carriage with the edges (FIG. **6**) of the U-Shaped channel members **36R** and **36L** to prevent derailment. Vertical load shafts, bearing rollers, and collars assemblies **70** carry the box solar oven assembly **180** weight along the structural extension assembly **34**. The roller bracket **62** is sized and configured to provide interference with the U-shaped channel rail members **36R** and **36L** as stated earlier to prevent detachment and removal from the structural extension assembly **34**.

Referring to FIGS. **2**, **3**, **11**, **12**, and **13** the box solar oven assembly **180** includes an insulated assembled foam box **182** (FIG. **13**) which includes a foam box top **184**, foam box sides **186R** and **186L** with clearance holes for the stationary horizontal pivot bearing bolts **234** supported by a yoke member **228**, and a foam box bottom **188** assembled at all the corner joints with long wood screws or other suitable connecting methods. The foam material used is rigid polyisocyanurate Aluminum foil faced foam board used in building construction. Energy Shield® by Atlas Roofing Corporation®, or Thermasheath and TSX 100 and 200, by Rmax Inc., or other standard building foam with two-sided foil can be used for the insulated foam box **182** structure. It can be any standard thickness 1.5 inches or greater.

A formed sheet metal hoop strap **192** assembles around (slides onto) the foam box main body area and is then secured by tightening the two screws at a hoop clamp opening (FIG. **2** under bottom collector panel). The clamping system includes two parallel flanges bent 90 degrees outward at each end of the hoop strap material with two clearance holes with screws in each for tightening the clamp together. The clamping system is tightened until it cinches (clamps) tight therefore providing a hoop stress compression force strength around the entire main body of the insulated foam box structure. This hoop strap **192** provides a significant strength improvement to the foam box structure **182** without adding excessive weight or requiring other less desirable methods for structural integrity and strength. There are two holes located in the hoop strap **192** for flange

bearings **194** (FIG. **13**) to be inserted which are for rotating the box solar oven **180** (FIG. **12**) on the stationary horizontal pivot bearing bolts **234** supported by the yoke member **228**. The hoop strap **192** depth is larger (wider) than the top width of the foam box top **184** therefore creating a recessed well at the front glazier opening having a depth of the thickness of the stacked two glaziers **196** of clear plate glass or equivalent with the glazier spacer frame **198** in between. This recessed well provides for insertion, at the front of the insulated foam box **182** edge face, for secure placement in two degrees of freedom of the inner and outer glaziers **196** and glazier spacer frame **198** assemblage. A tight seal for heat retention of the inner glazier **196** to the foam box edge along with the glazier spacer frame **198** between both the inner and outer glaziers **196** is made with a solar collector panel mount retainer and insulating enclosure frame assembly **202** (FIG. **13**) by using a solar collector panel mount retainer and insulating enclosure frame **204**, which retains and traps the glazier system securely and tightly in place down into the recess well and onto the foam surface when slid on over the hoop strap's **192** outer surface down to the outer glazier surface. The insulating enclosure frame **204** is then secured with sheet metal screws (not shown) into the hoop strap **192** on both side ends. A solar collector panels assembly **208** made up of solar collector panels **210** segments is assembled by inserting the lower flanges of the solar collector panels **210** under the solar collector panel mount retainer and insulating enclosure frame **204** opening flanges before assembling the insulating enclosure frame assembly **202** onto the hoop strap **192**. The solar collector panel mount retainer and insulating enclosure frame **204** after attachment, is what holds the glazier and solar collector panel systems securely in place by using the hoop strap **192** main structure.

A formed sheet metal cover protector assembly **212** provides exterior protection of the foam material not covered by the hoop strap **192**. A cover protector **214** is inserted onto the insulated foam box **182** with its sides passing over the hoop strap **192** material and when in position the cover protector **214** is then secured with sheet metal screws (not shown) into each side to the hoop strap **192** structure. A door assembly **218** slides into the rear opening of the insulated foam box snugly with a degree of interference for heat retention using a door handle **222**. An added appropriate surface of plastic or other suitable material (not shown) can be inserted into the assembled foam box **182** on the foam/foil surfaces if desired to protect and insulate to facilitate and accommodate operation wear and cleaning.

Referring to FIGS. **3**, **11**, and **13**, A light alignment indicator assembly **256** is used to indicate azimuth and solar altitude alignment of the box solar oven assembly **180** with respect to the related perpendicularity of the glazier surface to the sun's incoming rays. It includes a tube scope box mounting bracket **258** which positions and mounts a light indicator tube **260** attached with clamping collars (not shown) or other method around the tube at the mounting bracket surfaces with the light indicator tube **260** positioned perpendicular to the glazier surface in two directions. A translucent light target assembly **262** provides for a translucent target **264** to be parallel and away from the tube **260** end plane (FIG. **13**). The translucent light target assembly **262** includes a clamp type target mounting bracket **266** which connects or clamps onto the light indicator tube **260** extending past the light indicator tube **260** end to position the translucent target **264** parallel and away from the tube **260** end plane needed for projecting the sun rays (light beam) out of the tube onto the translucent target **264** for

visual reading on either surface of the target material (front or back). The light alignment indicator assembly **256** is attached with the tube scope mounting bracket **258** into the box solar oven assembly **180** solar collector panel mount retainer and insulating enclosure frame assembly **202** with screws.

Referring to FIG. **12**, an azimuth bearing and pedestal base assembly **242** for positioning and rotating the box solar oven assembly **180** includes a pedestal base **248** providing a stable ballast stand frame structure screwed or connected by other standard methods to an azimuth 12 inch bearing bottom mount plate **246**, then is connected to an azimuth 12 inch bearing **250**, which is then mounted to an azimuth 12 inch bearing top mount plate **244** which provides a mounting surface to connect to the yoke member **228**. A center of gravity biaser spring **252**, screwed and mounted to the plate **244** surface is provided to keep a solar altitude cable winch cable **100** tight at all times and therefore fully operational at any position in the 90-degree rotation range. The center of gravity biaser spring **252** is designed to keep a constant force or biased push on the box solar oven assembly **180** in one direction throughout the entire adjustment range, thereby eliminating a characteristic reverse rotating reaction caused by a change in the center of gravity moment due to the unique box solar oven **180** design shape.

A solar altitude locking bar **254** in FIG. **12** is connected with a pivoting screw at one end onto the box solar oven assembly **180** and to the yoke member **228** with its adjusting slot. This provides for solar altitude locking bar **254** being able to slide in a long slot at the yoke member **228** when the box solar oven assembly **180** is rotated. By tightening a locking finger screw (not shown) in the long bar slot at the yoke member **228**, a clamping action of the bar to the yoke member occurs, therefore locking the box solar oven assembly **180** into a set position. This is used for manually locking the rotating altitude position when needed during manual operations, handling, or maintenance.

FIG. **11** shows a food rack and supports assembly **230** inside the box solar oven assembly **180**. The food rack and supports assembly **230** includes two horizontal pivot bearing bolts **234** supported by the yoke member **228** (FIG. **12**) as discussed earlier. These bolts are mounted stationary to the yoke member **228** with machine nuts and protrude through the flange bearing assembly and out into the box solar oven assembly **180** cooking or heating interior compartment for assembling the food rack and supports assembly **230**. Two food rack side plates **236** are rigidly connected with machine nuts to the two horizontal pivot bearing bolts **234**. Two food rack cross rods **238** are rigidly connected with machine nuts at each corner of the lower portion of two food rack side plates **236**. A food rack horizontal plate **240** then sits on top the two food rack cross rods **238** maintaining its position vertically by its own weight. The food rack horizontal plate **240** has the two longitudinal side edges bent 90 degrees down or can have four leg type features extending or protruding from the bottom surface of the plate for trapping the plate itself onto (straddling) the two food rack cross rods **238** when in operation. Horizontal plate **240** is trapped (secured) between the two food rack side plates **236** and each of the outer diameter sides of the two food rack cross rods **238**.

Referring to FIGS. **2**, **3**, **4** and **5**, the extended positioning system **32** includes a remote-control mechanism and devices **120** (FIG. **2**). Remote control mechanism and devices **120** is designed to operate for position, adjusting, and solar align-

ment in any infinite continuous location or position along the extended positioning system **32** with the operator located within the building structure.

A linear positioning mechanism used to position the box solar oven assembly **180** along the extended positioning system **32** includes and referring to FIGS. **3**, **4** and **5**, is a linear hand wheel **122** attached with a set screw or other standard method to a cable drive spool **124** which is then slip fit over the vertical pivoting member **42** for rotation of the cable drive spool **124** when in use. A cable drive spool collar **56** attached with a retaining screw to the vertical pivoting member **42** provides a thrust bearing surface for the turning spool **124** to run and slide on thereby reducing friction when rotating while also simultaneously setting the position of cable drive spool **124** on the assembly. A carriage drive cable **130** wraps a series of turns around the cable drive spool **124** in a tight fashion therefore providing frictional attachment to pull all the weight of the box solar oven assembly **180** on moveable carriage **58** in either linear direction without slippage. One end of the carriage drive cable **130** is attached or connected with clamps or a hook method to the vertical load shaft **72** (FIG. **9**) closest to the cable drive spool **124** of the moveable carriage **58**. The second end of the carriage drive cable **130** passes under the moveable carriage **58** and out the other side and down the structural extension assembly **34** to the end where cable loop pulley **126** is mounted onto the structural extension assembly **34** end with cable loop pulley mount plate bracket **128** by conventional methods and is looped around the cable loop pulley **126** to return to the second vertical load shaft **72** for again attachment to the moveable carriage **58**. This system provides pulling tension of the cable for either direction of movement of moveable carriage **58** when the cable drive spool **124** is rotated in either direction.

An extendable lever handle **156** mechanism is used by the operator for polar angular rotation positioning of the extended positioning system **32**. Referring to FIGS. **2**, **4**, and **5**, this control mechanism includes an extendable lever handle **156** with a set screw attached access knob positioning collar **158** at the user end. The other end of extendable lever handle **156** is assembled with a pivot pin into a sliding drive block pivot yoke **160** providing for the extendable lever handle **156** to be pivoted (or rotated) 90 degrees from horizontal to vertical or vice versa when in use. The sliding drive block pivot yoke **160** fits and is assembled into a wrench drive plug **162** and after insertion a press fit retaining pin (not shown) is put into the sliding drive block pivot yoke **160** block body which captures the yoke **160** into the wrench drive plug **162**. Then wrench drive plug **162** is then mounted and attached using two blind, screw tapped holes with set screws which are inserted through clearance holes in the diameter of the vertical pivoting member **42** of the pivot weldment **40** at the top and tightened into the wrench drive plug **162** thereby securing them together.

Referring to FIGS. **2**, **4**, **6** and **7**, an azimuth positioning remote control mechanism includes an azimuth hand wheel and hand wheel drive shaft assembly **132**, an azimuth worm gear drive mechanism **104**, an azimuth bearing drive roller assembly **102**, and an azimuth 12 inch bearing **250** (FIG. **12**).

The azimuth hand wheel and hand wheel drive shaft assembly **132** includes the azimuth hand wheel **134** attached with a retaining screw to an azimuth hand wheel drive shaft **136** which extends down through a running slip fit clearance hole in the top of an azimuth miter gear drive shaft bracket **138** interconnecting with a first azimuth miter gear **140** which engages a second miter gear **140** therefore together

changing the rotating power direction 90 degrees from vertical to horizontal. The second azimuth miter gear **140** is connected to a special azimuth D-profile drive shaft **142** that then runs the entire length of the structural extension assembly **34**. The azimuth D-profile drive shaft **142** is mounted in running slip fit bearing clearance holes at each end at the bottom of the azimuth miter gear drive shaft bracket **138** and at the cable loop pulley mount plate bracket **128** to allow for power transfer rotation using the bearing holes. The miter gears **140** are fixed to the shafts with set screws or other mechanical common methods.

The azimuth worm gear drive mechanism **104** has a worm **106** that is mounted with its bore onto the D-profile drive shaft **142** with a running slip fit bearing clearance so it slides along the D-profile drive shaft **142** when the moveable carriage **58** is driven linearly with the cable drive spool **124**. The bore of the worm is configured to either have a flat spot or keyed feature in the diameter, or a mechanical clip method (not shown) on its hub to provide a key type feature that prevents the worm from rotating around the D-profile shape of shaft **142** when rotational force is applied, yet still allowing free sliding longitudinally along the D-profile drive shaft **142**. The design transfers the rotating power from the D-profile drive shaft **142** to the worm at any location along the extended positioning system **32**. The rotating azimuth worm **106** engages an azimuth worm gear **108** which is connected to a drive roller shaft **114** and is passed through a running slip fit bearing clearance hole in an azimuth worm gear housing **110** (FIG. **8**) that is machine screwed or attached by other common methods to the base plate **80** of the moveable carriage **58**. A drive roller collar **118** secures and positions the azimuth worm gear **108** and drive roller shaft **114** together to the azimuth worm **106**. A Drive roller **116** is attached in a secure standard method to the top of the drive roller shaft **114** to transfer the rotating power to the side edge of azimuth 12 inch bearing **250** (FIG. **12**) and rotate the box solar oven assembly **180** for azimuth positioning and adjustments. At the interface between drive roller **116** and the side edge of azimuth 12 inch bearing **250**, pressure is applied into the edge of the side edge of azimuth 12 inch bearing **250** with enough force to provide friction to drive the system. The force of the drive roller **116** may be achieved by various design methods including using a rubber roller preloaded at the side edge of azimuth 12 inch bearing **250** by setup adjustment of the azimuth worm gear housing **110** to the base plate **80** of the moveable carriage **58**. Another design method (not shown) is to wedge shape the drive roller **116** in a downward fashion to jam (or wedge) the drive roller **116** into and against the side edge of the azimuth 12 inch bearing **250** using the downward force of gravity and/or another collar (not shown) to preset the downward wedge force in preloading setup. The rotational power can now be transferred from the operator's hand (azimuth hand wheel **134**) to the azimuth 12 inch bearing **250** on the moveable carriage **58**, at any location along the entire extended positioning system **32** distance.

Referring to FIGS. **2**, **4**, **5**, **6**, **7**, **8**, and **9**, the solar altitude positioning control mechanism includes a solar altitude hand wheel and hand wheel drive shaft assembly **144** (shown in FIG. **2**), a solar altitude worm gear drive mechanism **86**, a cable winch drum and shaft assembly **94** and a cable winch cable **100** which is attached to a solar altitude cable attach bracket **216** (FIG. **12**).

The solar altitude hand wheel and hand wheel drive shaft assembly **144** includes a solar altitude hand wheel **146** attached with a retaining screw to a solar altitude hand wheel drive shaft **148** which extends down through a running slip

fit clearance hole in the top of a solar altitude miter gear drive shaft bracket **150** interconnecting with a first solar altitude miter gear **152** which engages a second miter gear **152** therefore together changing the rotating power direction 90 degrees from vertical to horizontal. The second solar altitude miter gear **152** is connected to a special solar altitude D-profile drive shaft **154** that runs the entire length of the structural extension assembly **34**. The solar altitude D-profile drive shaft **154** is mounted in running slip fit bearing clearance holes at each end at the bottom of the solar altitude miter gear drive shaft bracket **150** and at the cable loop pulley mount plate bracket **128** to allow for power transfer rotation using the bearing holes. The miter gears **152** are fixed to the shafts with set screws or other mechanical common methods.

The solar altitude worm gear drive mechanism **86** has a worm **88** that is mounted with its bore onto the D-profile drive shaft **154** with a running slip fit bearing clearance so it slides along the D-profile drive shaft **154** when the moveable carriage **58** is driven linearly with the cable drive spool **124**. The bore of the worm is configured to either have a flat spot or keyed feature in the diameter, or a mechanical clip method (not shown) on its hub to provide a key type feature that prevents the worm from rotating around the D-profile shape of shaft **154** when rotational force is applied, yet still allowing free sliding longitudinally along the D-profile drive shaft **154**. The design transfers the rotating power from the D-profile drive shaft **154** to the worm at any location along the extended positioning system **32**. The rotating solar altitude worm **88** engages a solar altitude worm gear **90** which is connected to a cable winch shaft **96** which is passed through a running slip fit bearing clearance hole in a solar altitude worm gear housing **92** that is machine screwed or attached by other common methods to the base plate **80** of the moveable carriage **58**. The cable winch shaft **96** is also passed through a running slip fit bearing clearance hole in the azimuth worm gear housing **110** that is machine screwed or attached by other common methods to the base plate **80** of the moveable carriage **58** (FIG. **8**). A cable winch shaft **96** retaining collar, where the cable winch shaft **96** passes through the solar altitude worm gear housing **92** (not shown) secures and positions the solar altitude worm gear **90** and cable winch shaft **96** together to the solar altitude worm **88**.

Referring to FIGS. **9** and **12**, a cable winch drum **98** is attached in a secure standard method to the cable winch shaft **96** to transfer the rotating power to a linear pull of the solar altitude cable winch cable **100**, which then pulls to rotate the box solar oven assembly **180** for solar altitude positioning and adjustments. The solar altitude cable winch cable **100** is attached to the cable winch drum **98** with a set screw clamping design consisting of a tapped machine thread hole at the end of the drum intersecting a cable retention hole therefore being able to trap the cable securely to the drum.

The solar altitude cable winch cable **100** is wrapped around the cable winch drum **98** as many times as needed to provide enough linear cable length to rotate the box solar oven assembly **180** in any position within 90 degrees from horizontal to vertical for all possible operation applications. Solar altitude cable winch cable **100** then passes through the moveable carriage base plate **80**, up through the azimuth bearing and pedestal base assembly **242**, and attaches to the underside of the box solar oven assembly **180** at the solar altitude cable attach bracket **216** which is attached with screws to the cover protector **214** again with a set screw clamping design consisting of a tapped machine thread hole intersecting a cable retention hole for clamping the cable end

13

securely into the solar altitude cable attach bracket **216**. The rotational power can now be transferred from the operator's hand (solar altitude hand wheel **146**) to the box solar oven assembly **180** at the solar altitude cable attach bracket **216** for rotation even when the moveable carriage **58** is at any location along the entire extended positioning system **32** distance. Furthermore, in this design, when the box solar oven assembly **180** is rotated with the azimuth control, the solar altitude cable winch cable **100** can flex and twist from the drum to the cable attach bracket **216** for the required flexibility needed to position the azimuth simultaneously with solar altitude ranging from less than 90 degrees to greater than 270 degrees of azimuth rotation positions.

Referring to FIG. 1, a protective storage shelter cover **268** is mounted to the side of the opening on the building above the height of the box solar oven assembly **180** with standard fastening methods. The box solar oven assembly **180** is manipulated with the extended positioning system **32** under the protective storage shelter cover **268** for storage until later use.

Referring to FIGS. 14, 15, and 16, these diagrams illustrate and indicate the relative increased reach capabilities provided by solar oven system **30** to retrieve solar exposure around a general building structure. FIG. 14 shows the solar oven system **30** extending out in order to meet both summer and winter sun paths which eliminates shadowing from the building overhang and corners. FIGS. 15 and 16, show the potential angular projections of solar radiation exposure in perspective and top views. These views indicate how, in varied application directions, the system **30** can reach back (around a building corner) approximately 11 degrees at a 6 ft. extension of the extended positioning system **32** for increased solar exposure time and thus accommodate more varied building directions and geographic locations for universal utility. FIG. 16 shows how an east or west solar oven system **30** application can get increased solar exposure time due to reach back around a building corner.

The solar oven system operates as follows. The operator opens the building opening from the kitchen cooking area and reaches to operate the system with remote control mechanism and devices **120** at the opening bottom edge and retrieves the solar oven system **30** from protective storage for use (FIG. 2).

The extendable lever handle **156** end access knob being held in an accessible location with an access knob positioning collar **158**, is pulled vertically straight up fully out of the pivot weldment **40** and then the extendable lever handle **156** is rotated 90 degrees in the sliding drive block pivot yoke **160** into the horizontal position for use as shown in FIG. 2. The extendable lever handle **156** is then pulled or pushed sideways left to right, to provide pivoting torque transmitted through the sliding drive block pivot yoke **160** into the wrench drive plug **162** to the pivot weldment **40** by the user which then rotates the extended positioning system **32**, made up generally of the pivot weldment **40**, structural extension assembly **34**, moveable carriage **58**, along with the box solar oven assembly **180**. This moves the solar oven system **30** out of protective storage, away from, and perpendicular to the building wall, in front of the opening for cooking use as in the position shown in FIG. 2. The extendable lever handle **156** is then again rotated 90 degrees in the sliding drive block pivot yoke **160** into the vertical position and lowered back down into the pivot weldment **40** putting it into its original storage position when the access knob positioning collar **158** contacts the wrench drive plug **162** for later use and therefore not interfering with the other operational procedures and features.

14

Then the two remote control mechanisms and devices **120** for azimuth and solar altitude are used to align the back-door surface of the box solar oven assembly **180** to be parallel to the wall opening as in FIG. 2.

The azimuth hand wheel **134** (FIG. 4) and solar altitude hand wheel **146** are rotated individually, each driving its two drive shafts, azimuth hand wheel drive shaft **136**, azimuth D-profile drive shaft **142**, solar altitude hand wheel drive shaft **148**, and solar altitude D-profile drive shaft **154**. The D-profile drive shafts **142** and **154** transmit the rotating power coming through the miter gears **140** and **152** to turn worm gear mechanisms **104** and **86** (FIG. 7), respectively. The azimuth worm **106** turns the azimuth worm gear **108** that turns the drive roller shaft **114** which then turns drive roller **116**, thereby turning the azimuth 12 inch bearing **250** for azimuth positioning of the box solar oven assembly **180**.

The solar altitude worm **88** (FIG. 8) turns the solar altitude worm gear **90** which turns the cable winch drum and shaft assembly **94**, which then, when rotating, pulls the cable winch cable **100** in a linear direction causing the box solar oven assembly **180** to rotate into the desired solar altitude position.

The operator then rotates the linear hand wheel **122** (FIG. 3), therefore turning the cable drive spool **124** and pulling the carriage drive cable **130** which, in turn, moves the box solar oven assembly **180** which is on the moveable carriage **58** and pulls it towards and up to the wall opening ready for use.

The door assembly **218** is then pulled out of the box solar oven assembly **180** and temporarily positioned somewhere in the food preparation area until later use (if a hinged door design is used than this no longer applies). The prepared food containers are then loaded and positioned on the food rack horizontal plate **240** (FIG. 11) being stacked or positioned to the desired liking. The door assembly **218** is then reinserted back into the box solar oven assembly **180**, therefore closing the box solar oven **180** for the cooking operation.

Again, rotating the linear hand wheel **122** (FIG. 3) deploys the loaded box solar oven assembly **180** out into the open environment by pulling the moveable carriage **58** out to the end of the extended positioning system **32**. The wall mount system **164** (FIG. 2) provides the necessary strength to accommodate the deployed loaded box solar oven assembly **180** out away from the building structure by all vertical load forces directed down in the ground foundation block **178**, horizontal loading held in equilibrium by the pivot post **174** and pivot post straps **176**, pivot post saddle weldment **166**, pivot weldment **40**, and beam suspension support truss assembly **48**. The azimuth hand wheel **134** (FIG. 4) and solar altitude hand wheel **146** are now rotated again by the operator to align the box solar oven assembly **180** in position (towards the sun) for optimum solar energy retrieval. As the azimuth hand wheel **134** and solar altitude hand wheel **146** are now being rotated, the operator visually uses the light alignment indicator assembly **256** (FIG. 13) and the light beam spot on either side of translucent target **264** to indicate and communicate the amount of azimuth and solar altitude adjustment alignment required for the box solar oven assembly **180** with respect to its related perpendicularity of the glazier surface to the sun's incoming rays.

Solar cooking is now in full operation without spillage, leaving the kitchen, or other deployment problems associated with the prior art. Now, periodically, the user visually checks and monitors the light alignment indicator assembly **256** translucent target **264** light beam alignment patterns and makes the desired necessary adjustments using the azimuth

hand wheel **134** and solar altitude hand wheel **146** keeping the oven system collecting the greatest quantity of solar radiation. The indication of light rays which pass through the light indicator tube onto the translucent target **264** in a full round spot (not round or clipped off) indicates that the box solar oven assembly **180** is accurately aligned to the sun for optimum perpendicularity, therefore, energy retrieval.

As an alternative embodiment (FIG. 6), this manual solar adjustment and alignment process with azimuth hand wheel **134** and solar altitude hand wheel **146** can be configured to be semiautomatic or fully automatic by installing sun tracking devices to the azimuth and solar altitude control mechanisms such as clock motors on each hand wheel, weather spring driven or electric, or other apparatuses to rotate and track the sun path as needed with feedback or no feedback. This tracking would be operated after the above deployment with the manual controls to a sun path start position for the day or cook time.

When the cooking process is completed, the azimuth hand wheel **134** and solar altitude hand wheel **146** are then rotated by the operator to align the back-door surface of the box solar oven assembly **180** to be parallel to the wall opening as in FIG. 2. Then the operator again rotates, the linear hand wheel **122**, therefore turning the cable drive spool **124** and pulling the carriage drive cable **130** which moves the box solar oven assembly **180** back towards and up to the wall opening ready for unloading. The door assembly **218** is then pulled out of the box solar oven assembly **180** and temporarily positioned somewhere in the food preparation area until later (if a hinged door design is used than this no longer applies). The prepared food containers are then unloaded back into the cooking area by removing them off the food rack horizontal plate **240**. The door assembly **218** is then reinserted back into the box solar oven assembly **180**, therefore closing the box solar oven **180** for storage.

Then the operator again rotates, the linear hand wheel **122**, therefore turning the cable drive spool **124** moving the box solar oven assembly **180** back out away from the building wall and again pulls up extendable lever handle **156** end access knob which is pulled vertically straight up fully out of the pivot weldment **40** and then retracted back down 90 degrees in the sliding drive block pivot yoke **160** into the horizontal position for use pivoting the solar oven system **30** to the protective storage area for later use. The azimuth hand wheel **134** and solar altitude hand wheel **146** may be rotated by the operator to align the box solar oven assembly **180** under the protective storage shelter cover **268** (FIG. 1).

The center of gravity biaser spring **252**, screwed to the plate **244** surface, keeps the solar altitude cable winch cable **100** constantly tight throughout the entire 90-degree rotation range when the altitude position is high enough to shift the center of gravity moment in reverse (a geometric characteristic of the oven shape). The center of gravity biaser spring **252** (FIG. 3) pushes on the bottom of the box solar oven assembly **180** upward therefore removing or eliminating the reverse force moment and maintaining the forward force moment (biased in one direction), therefore keeping cable winch cable **100** remaining tight and fully operational in any position without losing control due to cable **100** slack.

The solar altitude locking bar **254** (FIG. 12) is connected with a pivoting screw onto the box solar oven assembly **180** and slides in a slot at the yoke member **228** when the box solar oven assembly **180** is rotated. By tightening a locking finger screw (not shown) in the long solar altitude locking bar **254** slot, a clamping action of the solar altitude locking bar **254** to the yoke member **228** occurs, therefore locking the box solar oven assembly **180** into a set position. This is

used for manually locking the rotating altitude position when needed during handling, maintenance, or assembly of the system.

The solar oven system embodiment provides a highly efficient, effective, and adaptive solar oven cooking apparatus that is easy for anyone to frequently use as a useful cooking device when doing standard ongoing cooking operations.

Reaching out away from the building structure into the outside environment for solar exposure when operated with remote controls without leaving the cooking area, and the adaptable flexible universality of the system features greatly enhancing practicality and usability, all provide increased significant development of solar oven technology in the prior art, therefore, substantially impacting energy savings, alternative energy use, and energy conservation.

The solar oven system embodiment provides a major advantage of integrating the needed solutions of the various and numerous problems encountered with solar cooking that, up until now were prohibitive to the operating requirements of each step in the entire solar cooking process. It is one complete seamless cohesive operation that has been solved with this new embodiment apparatus by integrating the functional process steps together from a kitchen area.

Featured examples of this new embodiment including the box solar oven structure rotating around the food contents during vertical solar altitude adjustments, all food handling being done in the kitchen area, and the ability to move out and position the box solar oven out away from the building and retrieve it back from inside the building are just three of the major advantages illustrating the practical innovative design of this embodiment.

In addition to the above-described embodiments, many other variations are possible. For example, solar oven system **30** and or extended positioning system **32** may be used for other food preparation needs such as cooling of hot dishes, making sun tea, drying fruit, drying dishes, or pasteurizing water.

The extended positioning system **32** may be used alone to adapt to and accommodate other portable box solar ovens built or purchased which are unrelated generic types to this solar oven system. If yoke member **228** (FIG. 12) is disconnected from the azimuth 12 inch bearing top mount plate **244**, therefore enabling removal of the remainder of the box solar oven assembly **180**, then any portable solar oven placed on top of the azimuth 12 inch bearing top mount plate **244**, which is connected to the moveable carriage **58**, would provide for the operator to be able to use three of the manual remote control mechanisms and devices **120**, including the Linear hand wheel **122** for carriage movement, azimuth hand wheel **134** for adjusting azimuth, and the extendable lever handle **156** for polar angular rotation of the structural extension **34**. This adaptation provides for expanded use of the described embodiment utilizing a wider range of market adaptations of generic prior art portable box solar ovens which further accelerates solar oven technology in the future.

The extended positioning system **32**, with its universal utility including its manipulating and control features, may also provide other wider uses such as photo voltaic solar cell positioning and operation, or other applications requiring extension and reach out away from buildings or other structures.

This embodiment, with its utility, can be adapted and reconfigured at the wall mount by eliminating the ground foundation block **178** loading path for multistory, above ground building and apartment use applications providing

access to sunlight to residences and the like for solar cooking operations that would not normally be available to these applications. This further expands the solar oven technology.

Furthermore, the solar oven system **30** may also be used and mounted at any alternative location of the building structure, deck structure, wall, or post for added utility in various adapted settings. This will expand the alternatives available for solar radiation exposure.

Further, the option of creating a new cut wall opening designated solely for this solar oven system **30** provides the added benefit of having the box solar oven assembly **180** protective storage shelter cover **268** over and around the opening for ease and effective storage when pulled back to the building when the unit is not in use (not blocking a window opening when leaving the unit ready for the next use). Also, a new designated opening can provide better operator reach into the box solar oven **180** depending upon the interior layout of the cooking area. The protective storage shelter cover **268** can also be installed directly over and around the window opening if desired for ease and speed of the operation regarding the unit storage steps being removed.

Box solar oven assembly **180** can also be used and operated in a standalone configuration in the described embodiment placed anywhere such as a prior art portable unit and can be aligned by rotating manually then locked into position using the solar altitude locking bar **254** (FIG. **12**).

Another variation of an embodiment of the solar oven system **30** would be to have the extended positioning system **32** structural extension assembly **34** lengthened for further reach out into the environment for solar radiation availability providing (if out far enough) approaching 360 degrees of solar exposure. By adding a section to the structural extension assembly **34** or having a telescoping section that extends out from the main structural extension **34**, this could be accomplished. Due to the extensive structural extension length, a designed support assembly with wheel casters extending down to the ground or other surface and attached at some intermediate location along the structural extension **34** or at an end of structural extension **34** would provide added support for a long structural extension **34** while continuing to provide for movement when making polar angular adjustments of structural extension **34** with the extendable lever handle **156**.

Referring to FIG. **12**, the azimuth bearing and pedestal base assembly **242** can be changed in various ways to provide alternative ways to accommodate different applications and reduce parts and cost. For example, one alternative is to remove (not have) the pedestal base **248** and azimuth 12 inch bearing bottom mount plate **246** whereby then attaching the azimuth 12 inch bearing **250** directly to the moveable carriage base plate **80**. Another is to remove the two top and bottom azimuth 12 inch bearing mount plates **244** and **246** along with the pedestal base **248** and attach the yoke member **228** and moveable carriage base plate **80** directly to the azimuth 12 inch bearing **250** (not removable readily from the extended positioning system **32** and no base for standalone operation). These configurations reduce the amount of parts and cost of the azimuth bearing and pedestal base assembly **242** which are not necessarily required for some stand alone or other application functions. Or, the pedestal base **248** can be attached directly to the yoke member **228** (no azimuth 12 inch bearing **250** or azimuth function unless a separate bearing is inserted under the pedestal base **248**) for a standalone system (operating without the extended positioning system **32**).

Another variation of the solar oven system **30** is that door assembly **218** can include a hinge and latch design at the top or bottom of the door edge to increase and simplify operation efficiency which keeps the door attached at all times to the oven body and speeds up the loading process. Either design of press fit insertion (described in the above description) or hinged attachment can be used depending on cost and process method application requirements.

Different alternative wall mount system design configurations to accommodate various applications include a steel stake retention rod driven into the ground replacing the saddle bottom retaining bracket **172** which was previously employed. This stake retention method includes a horizontal flange (not shown which is welded onto the M-shape saddle **168**) protruding from one side of the M-shape saddle **168** near the ground surface with a hole for the insertion and driving of a retention rod driving it deep into the ground material for secure retention of the bottom of the pivot post saddle weldment **166**. This design is needed when the building wall design and material do not accommodate the saddle bottom retaining bracket **172** design shown in the preferred embodiment described above. Also, the saddle top retaining stud **170** can be converted to another shape design of a flange with a hole or other for accommodating different building designs. Screws, bolts, other type fasteners, or other standard prior art retaining methods can be used if necessary to attach the pivot post saddle weldment **166** to the wall as well.

The azimuth worm gear drive mechanism **104** (FIG. **7**) can be changed to a miter gear 90 degree (no gear reduction) or bevel gear (reduction) alternative design if desired. This provides an alternative for a direct drive gear ratio of one to one in the drive system or other gear reduction ratio to the azimuth 12 inch bearing **250**. This reduces the turning revolutions the operator must make to change azimuth position. These designs also allow for cost reduction in manufacture.

Sun tracking clock motors, servo motors (spring force, electric, or other), or other server mechanisms can be mounted and attached to the azimuth and solar altitude hand wheel and hand wheel drive shaft assemblies wheels **132** and **144** (FIG. **2**) for driving and turning the remote-control devices to track the sun path for automatic adjusting to sun position throughout the day therefore, not requiring operator intervention for the entire cooking time.

The positioning system can include a sun tracking system that utilizes servo motors that adjust positioning of the solar oven radiation collection device. For example, a sun location system can be used to identify current location of the sun, and the servo motors (or other servo mechanisms) can adjust positioning of the solar oven radiation collection device based on information about location of the sun provided by the sun location system.

For example, a market manufactured automated sun tracking system using either a fixed control algorithm, fixed control mechanism, or dynamic tracking system design can be adapted and integrated into the solar oven system **30** (FIG. **2**) by attaching automatic sun tracking system components onto the extended positioning system **32** and box solar oven assembly **180**. Referring to FIG. **5** and FIG. **6** servomotors **270** and **274** are mounted to the azimuth hand wheel drive shaft **136** and solar altitude hand wheel drive shaft **148** with azimuth servomotor mount bracket **272** and solar altitude servomotor mount bracket **276** with machine screws or other standard attachment methods. The servomotor drive shafts are connected with azimuth servo drive coupling **280** and solar altitude servo drive coupling **282**



with set screws to the azimuth and solar altitude hand wheel drive shafts **136** and **148** for driving the azimuth and solar altitude hand wheel & hand wheel drive shaft assemblies **132** and **144** (FIG. 2). The azimuth and solar altitude servomotor mount brackets **272** and **276** are then attached to azimuth miter gear drive shaft bracket **138** and solar altitude miter gear drive shaft bracket **150** (FIG. 6) with machine screws or another standard attachment method to connect and hold the servomotors stationary with respect to the positioning system **32** frame when rotating. A feedback light sensor unit **278** (FIG. 11) mounted on the translucent target **264** (FIG. 13) under the end of the light indicator tube **260** receives light from the light indicator tube when in alignment communicating to the servomechanism to stay in position, or if partial light, adjust to align. This feedback light sensor unit **278** would be used for a dynamic system design requiring a feedback sensor circuit. A solar tracking controller **284** is then connected to the sensor circuit and servomotors for solar tracking control.

Further, servo motors can be employed that position using a GPS (Global Positioning System) control signal from a cell phone or other electronic device. Furthermore, a solar oven system software application on a cell phone could be employed to adjust and monitor temperature and sun alignment by the operator during the cooking process and operations using current telecommunications technology.

FIG. 17 shows an embodiment where a discrete electronic control unit has been added to a positioning system for solar oven system **300**. As shown in FIG. 17, solar oven system **300** is similar to the solar oven system shown in FIG. 1, having for example, a box solar oven assembly **308**, a solar collector panels assembly **310**, a structural extension assembly **334**, an extended positioning system **332**, a pivot post **374**, a ground foundation block **378**, and other similar features. Box solar oven assembly **308** functions as a solar oven radiation collection device.

In solar oven system **300**, electric motors can be used to automate adjustments to the position of box solar oven assembly **308**. For example, FIG. 18 shows a solar altitude electric motor **401**, a linear deploy electric motor **402** and a solar azimuth electric motor **403** used to adjust position of box solar oven assembly **308**. Linear deploy electric motor **402** is used to control linear movement of box solar oven assembly **308** along an axis of structural extension assembly **334** with a linear deploy lead screw **414**. Solar altitude electric motor **401** is used to adjust orientation of box solar oven assembly **308** to take into account changes in solar altitude with respect to time. Solar azimuth electric motor **403** is used to adjust orientation of box solar oven assembly **308** to take into account changes in solar azimuth with respect to time. A solar altitude override handle **411** can be used to disengage power transmission of solar altitude electric motor **401** and manually adjust for solar altitude, a linear deploy override handle **412** can be used to disengage power transmission of linear deploy electric motor **402** and manually adjust linear deploy and a solar azimuth override handle **413** can be used to disengage power transmission of solar azimuth electric motor **403** and manually adjust for solar azimuth. For example, motor **401**, motor **402** and motor **403** are electric gear motors.

FIG. 19 is a simplified block diagram of a controller system **400** that controls solar altitude electric motor **401**, linear deploy electric motor **402** and solar azimuth electric motor **403**.

A power source includes a transformer **420** converting AC power to DC power used in controller system **400**. A timer **421** functions as a dual timer to index sun tracking solar

altitude to follow the sun by index positioning the box solar oven along the sun path to enable solar cooking. A timer **422** functions as a single timer tracking reverse solar altitude which reverses (changes) the direction of solar altitude at solar noon for continuous sun following for the whole day (sun up to sun down). A timer **425** functions as a single timer that stops sun tracking of solar altitude and azimuth tracking at the end of cook time to prevent interference caused by excessive automatic translation of the solar oven system **300**. Timer **421** and timer **422** are used to control solar altitude electric motor **401** to allow positioning of box solar oven assembly **308** to take into account changes in sun altitude over cook time. An arrow **424** represents manual override positioning with solar altitude electric motor **401**. An override button switch **423** is used for rapid motor positioning by an operator using solar altitude electric motor **401**. Further, the option of Non-electric (no Motor) override is always available when needed by manually lifting up solar altitude override handle **411** to disconnect solar altitude electric motor **401** out of the drive train in order to be able to rotate by hand with the solar altitude override handle **411**. When solar altitude override handle **411** is released, reconnection of the solar altitude electric motor **401** is reengaged for electric control. Connection and disconnection are accomplished by the solar altitude electric motor **401** shaft having a "D" profile shape and the solar altitude override handle **411** shaft end having a "D" profile hole providing the two shafts to slide together and lock for power transmission and slide apart for power disconnect.

A timer **428** functions as a dual timer to index sun tracking for solar azimuth to follow the sun by index positioning the box solar oven along the sun path to enable solar cooking. Timer **428** is used to control solar azimuth electric motor **403** to allow positioning of box solar oven assembly **308** to take into account changes in sun azimuth over cook time.

An arrow **427** represents manual override positioning with solar azimuth electric motor **403**. An override button switch **426** is used by an operator for rapid motor positioning using solar azimuth electric motor **403**. Further, the option of Non-electric (no Motor) override is always available when needed by manually lifting up solar azimuth override handle **413** to disconnect solar azimuth electric motor **403** out of the drive train in order to be able to rotate by hand with the solar azimuth override handle **413**. When solar altitude override handle **413** is released, reconnection of the solar azimuth electric motor **403** is reengaged for electric control. Connection and disconnection are accomplished by the azimuth electric motor **403** shaft having a "D" profile shape and the solar azimuth override handle **413** shaft end having a "D" profile hole providing the two shafts to slide together and lock for power transmission and slide apart for power disconnect.

An arrow **430** represents direct manual rapid positioning with linear deploy electric motor **402** using the directional power switch **429**. Further, the option of Non-electric (no Motor) override is always available when needed by manually lifting up the linear deploy handle **412** to disconnect linear deploy electric motor **402** out of the drive train in order to be able to rotate by hand with the linear deploy handle **412**. When linear deploy handle **412** is released, reconnection of the linear deploy electric motor **402** is reengaged for electric control. Connection and disconnection are accomplished by the linear deploy electric motor **402** shaft having a "D" profile shape and the linear deploy handle **412** shaft end having a "D" profile hole providing the two shafts to slide together and lock for power transmission and slide apart for power disconnect.

While the rapid positioning override feature is shown implemented using button switch 423 and button switch 426, other types of switches can also be used, as will be understood by persons of ordinary skill in the art.

The sun tracking functions, after operator setup, are designed open loop (no feedback) automatically operating without operator intervention and without direct feedback from sun rays. Timer 421, timer 422, timer 425 and timer 428 are used for sun path tracking to follow the sun by index positioning the box solar oven along the sun path to enable solar cooking use. Each of these timers is implemented, for example, using off-the-shelf electronic time delay relay. For example, each electronic time delay relay is a solenoid coil relay with switch contacts operating based on a time setting set by the operator. There are different logic functions that can be obtained depending on the design of the timer relay used. Timer Relays can have a single time setting or two or more multiple time settings. For example, there are multi-function timers with various function modes including recycler, off and on delay, sequential start, interval on delay, and many more. Switches available are many as well, including, for example, Single Pole Double Throw (SPDT) switches or Double Pole Double Throw (DPDT) switches.

A directional power switch 429 functions to control lineal location of box solar oven assembly 308 along structural extension assembly 334. For example, automated motor homing can be used to control linear deploy electric motor 402. An arrow 430 represents manual direct positioning with linear deploy electric motor 402 by using the directional power switch 429.

FIG. 20A, FIG. 20B, FIG. 20C, FIG. 20D and FIG. 20E show a flowchart that shows and describes an example of an operator solar cooking process with the steps and functions in order to perform a solar cook when using solar oven system 300 with controller system 400. As pointed out above, alternative to using the flow described in FIG. 20A through FIG. 20E at any time full hand manual positioning is available and can be used at any time. This allows for continued operation of solar oven system 300 even when no electricity is available or if the owner desires to own or operate the solar oven system 300 without electronics.

The sun tracking portion of the system includes three different specific functions that work together. All three sun tracking functions, after operator setup, are designed open loop (no feedback from sun rays) and automatically operating without operator intervention. The sun path tracking function operates with “dual time, electronic time delay relays” (timers) to follow the sun by index positioning the box solar oven along the sun path to enable solar cooking. A second function reverses (changes) the direction of solar altitude at solar noon for continuous sun following for the whole day (sun up to sun down). The third function is an automatic Stop Sun Track, (end of the solar cook) to prevent interference caused by excessive automatic translation of the solar oven system 300. The operator is not required to be present or available to turn off controller system 400 tracking system at the end of a cook which removes a significant solar cooking constraint to solar cook with solar oven system 300.

In FIG. 20A through FIG. 20E, a logic block 442 signifies solar oven system 300 is in storage. A logic block 443, a logic block 444, a logic block 445, a logic block 446, a logic block 447 and a logic block 448 illustrate locating box solar oven assembly 308 in position for food loading. A logic block 449 represents loading food into box solar oven assembly 308. A logic block 450, a logic block 451, a logic block 452 and a logic block 453 represent alignment of box

solar oven assembly 308 to begin the cook process. A logic block 453, a logic block 454, a logic block 455, a logic block 456, a logic block 457 and a logic block 458 describe alignment and operation of sun tracking azimuth during cook time. A logic block 459, a logic block 460, a logic block 461, a logic block 462, a logic block 463, a logic block 464 and a logic block 465 describe alignment and operation of sun tracking altitude during cook time

A logic block 466, logic block 468 and a logic block 469 represent auto sun tracking stopping when the cook time ends. A logic block 470 a logic block 471, a logic block 472 and a logic block 473 represent locating box solar oven assembly 308 in position for food unloading. A logic block 475, a logic block 476, a logic block 477, a logic block 478 and a logic block 479 represent box solar oven assembly 308 returned to the storage position. A logic block 480 and a logic block 481 illustrate power disconnected when box solar oven assembly 308 is in the storage.

FIG. 21 shows box solar oven assembly 308 in position for food loading or for food unloading through a kitchen window 501. Casing 502 for control system 400. A power cord 503 can be plugged into a standard 120V AC power outlet. Control system 400 is connected to solar altitude electric motor 401, linear deploy electric motor 402 and solar azimuth electric motor 403 via a connector cable 504. All electronic components, except motors, are within casing 502 which also includes sensors switches and so on. Casing 502 is typically located in a kitchen protected from harsh outside weather.

The sun tracking performed by controller system 400 aligns with the sun path by indexing the box solar oven automatically in the solar azimuth and solar altitude axis positions incrementally to follow the sun path in order to receive solar radiation to solar cook. The timers, with relay contact switching, control the motor’s running time and dwell (wait or delay) time to execute the index movement in each increment with time durations of inactivity in between. The sequence is constantly repeated stepping along the sun path. Each indexing axis movement (altitude & azimuth) is accomplished electrically with an individual dual time timer relay component that includes a DPDT (Double Pole Double Throw) relay contact switch which is wired “normally open” (NO) and will be able to close the circuit for an increment of time to run (turn on) the motor for the specified set amount of time (T2) to move the box solar oven. Then, the relay contact switch turns off (times out) which opens the circuit again for another specified (set) time duration, a “Dwell or Wait” time (T1), until the next index move of T2 motor run time. A DPDT toggle switch, in the same circuit, is cross wired in configuration to reverse polarity of the circuit alternately for setting the desired direction of the box solar oven movement. This provides a clockwise (CW) or counter clockwise (CCW) motor rotation defining the box solar oven direction of movement. In this way periodically positioning of the solar oven radiation collection is adjusted to take into account changes in sun altitude and sun azimuth over cook time.

The second function is reverse (change) direction of solar altitude at solar noon. It operates as an open loop with a “single time, electronic time delay relay” timed to achieve a switching sequence from sun up to sun down. This accommodates the change in solar altitude sun direction (sun up to sun down) if this change occurs during a specific solar cook depending on when cooking time takes place during the selected day. This is accomplished electrically with an Off Start, (On Delay) timer function Mode single time Timer Relay component with a DPDT (Double Pole Double

Throw) contact relay switch in "series" in the circuit, which is cross wired relay in configuration to reverse polarity of the circuit alternately for changing (reversing) the direction of the box solar oven movement. This changes the solar altitude electric motor **401** rotation by providing clockwise or counter clockwise motor operation as desired. When the timer "times out", the DPDT (Double Pole Double Throw) contact relay switches the polarity of the circuit to make the solar altitude direction change to the down direction.

The third function is the automatic stop sun track at end of cook time. This turns off (stopping) the solar altitude and solar azimuth axis indexing movements to protect solar oven system **300** from interference conditions, therefore not requiring the operator to be present at the end of the cook. It uses a timed (time out) switching relay to turn off both indexing relay circuits to stop oven tracking movement.

This is accomplished electrically with an Off Start, (On Delay) timer function Mode single time Timer Relay component with a DPDT (Double Pole Double Throw) contact switch wired NC (Normally Closed) which, when times out, opens the two circuits to stop both axis from further indexing the box solar oven.

All three functions require no human operator intervention after the initial set up is performed to solar cook, which therefore, without needing the operator to make adjustments, frees an operator to have full convenience and freedom while the solar cooking takes place. This provides significant operational advantage to the solar cooking process.

FIG. 22A and FIG. 22B show circuitry used to accomplish the three functions described above. As discussed above, the first two electric drive functions are solar altitude and solar azimuth axis positioning control features implemented by solar altitude electric motor **401** and solar azimuth electric motor **403**. Solar altitude electric motor **401** and solar azimuth electric motor **403** operate in parallel. Override button switch **423** is used by an operator to override operation of solar altitude electric motor **401** and override button switch **426** is used by an operator to override operation of solar azimuth electric motor **403**, at any desired time, even when the sun tracking is in full operation.

DPDT toggle switches are used in implementing timer **421**, timer **422** and timer **428**, as shown in FIG. 22B, with each switch functioning for both the electric manual bypass and time delay relay timer directions by changing circuit polarity for change in direction as needed. These DPDT toggle switches, in the circuit, are cross wired in configuration to reverse polarity of the circuit alternately for setting the desired direction of the box solar oven movement. This provides a clockwise or counter clockwise motor rotation defining the box solar oven direction of movement. DPDT toggle switch **541** is used to implement both timers **421** and **422**. Cross wired switch **542** is used in series to further implement the directional change (sun up to sun down) of solar altitude electric motor **401**. DPDT toggle switch **547** is used to implement timer **428**.

Power for DPDT toggle switch **541** is provided through override button switch **423** or through time delay relay switch **531** and time delay relay switch **532** connected in series. Power for DPDT toggle switch **547** is provided through override button switch **426** or through time delay relay switch **533** and time delay relay switch **534** connected in series. When sun tracking for sun altitude is turned on using switch **524**, then time delay relay **525** controls time delay relay switch **532**, time delay relay **526** controls cross wired relay switch **542** and time delay relay **527** controls time delay relay switch **531**. When sun tracking for sun azimuth is turned on using switch **528**, then time delay relay

**529** controls time delay relay switch **533**. Time delay relay **525** controls time delay relay switch **534**. Time delay relay **525** is used to stop sun tracking of solar altitude and azimuth tracking at the end of cook time.

A unit power light **523** indicates when power switch **522** connects the circuit to a 120 volt power source. A sun track indicator light **530** indicates when sun track is on using switch **528**. For sun tracking, both switch **524** and switch **528** are in the "on" position.

In FIG. 22B, linear deploy directional power switch **429** is shown implemented as a DPDT On-Off-On spring back to center toggle switch cross wired in configuration to change polarity of the circuit changing direction as desired. This DPDT On-Off-On toggle switch, reverses polarity of the circuit alternately with position toggling to obtain the desired direction of the box solar oven movement while simultaneously powering the linear deploy electric motor **402**. This allows movement of box solar oven assembly **308** along the length of structural extension assembly **334** out away from the building opening and out into the outside environment.

For example, within controller system **400**, time delay relay **526**, time delay relay **527** and time delay relay **529** are configured so that solar collector panels assembly **310** maintain optimum oven cooking temperature without always being directly aligned to the sun accurately. Being out of accurate alignment perpendicularly with the sun is not very crucial to temperature drop, up to an angular limit, (depending upon weather conditions, solar seasonal and regional radiation availability, collector panel design, heat retention capability, etc.). This forgiving to sun perpendicularity alignment provides opportunity and advantage for simpler, low cost, more averaging practical automatic control systems to be created and developed for tracking the sun path while still providing optimal box solar oven performance to adequately solar cook.

For example, in a typical manual solar cook process, the total collected solar energy to maintain optimal oven temperature can be achieved and includes the following general solar cooking operation steps and technique to aggregate the necessary solar energy to solar cook:

An initial alignment is performed to align sun rays perpendicular where the start cook is positioned to align solar collector panels assembly **310** to directly collect sun rays, which results in optimum solar collection direct align performance.

Over time there occurs slow misalignment out of perpendicular alignment that takes place as the sun moves across the sky and the box solar oven stays stationary. This misalignment continues and can continue for up to one or even one and a half hours while still maintaining solar cooking temperature depending on sun path conditions, location, collectors, box efficiency design, etc.

A second alignment is then hand manually performed to align sun rays perpendicular where the cooker is positioned to align solar collector panels assembly **310** to directly collect sun rays, which results in optimum solar collection direct align performance.

Over time there occurs slow misalignment out of perpendicular alignment that takes place as the sun moves across the sky and the box solar oven stays stationary.

A third alignment is then hand manually performed again to align sun rays perpendicular where the cooker is positioned to align solar collector panels assembly **310** to directly collect sun rays, which results in optimum solar collection direct align performance.

Over time there occurs slow misalignment out of perpendicular alignment that takes place as the sun moves across the sky and the box solar oven stays stationary.

A fourth alignment is then further performed hand manually to align sun rays perpendicular where the cooker is positioned to align solar collector panels assembly **310** to directly collect sun rays, which results in optimum solar collection direct align performance.

Over time there occurs slow misalignment out of perpendicular alignment that takes place as the sun moves across the sky and the box solar oven stays stationary.

The example above with four alignments cover a four to six hour cook time. This requires use of time delay relay **526**, time delay relay **527** and time delay relay **529** to make alignment changes only four times over the course of this cooking time, while still maintaining sufficient cooking temperature to allow effective cooking.

Through research, observations and experience, in the prior art, it has been shown that approximately 10 to 20 degrees out of perpendicular alignment does not seem to result in a significant temperature drop within a moderately efficient box solar oven if the box solar oven is being realigned to perpendicularity incrementally throughout the cooking process. The estimated angles of 10 to 20 degrees stated above are based on crude observations and estimations to define these indicated angles. Further testing can be done within a particular usage environment to determine a minimum number of degrees out of alignment that will result in a temperature drop sufficient to negatively impact cooking. The minimum number of degrees or variance that is tolerable will vary with, geography, time of year, weather conditions, and sensitivity to temperature variance on the food being cooked. The greater the number of degrees out of alignment that can be tolerated, the longer the time that can elapse between alignments. The shorter the number of degrees out of alignment that can be tolerated, the shorter the time that can elapse between alignments.

Alternatively to alignment where at each position increment of the box solar oven assembly **308** being aligned so that at the optimum align time the solar collector panels assembly **310** is at an optimum perpendicular position to collect sun rays, the alignment can even be done with an offset to optimize the time between alignments and more closely follow the sun path. For example, in this case, the alignment could even be initially misaligned from perpendicular. Over time as the sun moves across the sky, alignment will improve until halfway through the sun path alignment cycle, perpendicular alignment will occur. Then as the sun continues moving across the sky, slow misalignment out of perpendicular alignment (misalignment) will take place as the sun moves across the sky and the box solar oven stays stationary. Therefore, by increasing optimum alignment increment frequency (indexing) of the box solar oven, the box solar oven keeps a closer following to the sun path overall by reducing the amount of misaligned stationary time of the box solar oven. This provides for closer overall alignment (pacing) flexibility with the changing sun path positions.

FIG. **23** is an example of a sun path chart that is used to configure operation of time delay relay **526**, time delay relay **527** and time delay relay **529**. The sun path shows how the solar elevation (altitude) varies with solar azimuth depending upon the calendar date. FIG. **23** shows that as controller system **400** tracking approaches solar noon time there is an overshoot that is not functionally as significant as the figure may be visually indicating. The maximum seasonal overshoot is less than 20 degrees and the amount of time in this

location does not reduce temperature in the box solar oven as discussed earlier. Also, notice that the slopes of the sun path season to season are nearly the same. This minimizes needing to make large season to season indexing speed adjustments, if at all, for obtaining an optimum cook. The solar noon time setting made in each specific daily individual cook by the operator makes up for and accommodates for the diurnal and seasonal changes in sun path.

For example, controller system **400** uses an algorithm of setting a dial, time duration from initial start of automatic tracking to solar noon, providing a specific control reference point no matter what time and initial start point is selected during the day. Controller system **400** resets the tracking system at each time of use reducing accumulated error from day to day changes all year. This provides the ability to always be able to follow the path of the sun cooking at any time of the day, season, or location.

The solar noon chart shown in FIG. **24** is an example of a chart that can be used by an operator to allow the operator to identify a specific solar noon time to be used for setting a solar noon dial time duration during a cook. This solar noon time information can be obtained for any global location wherever needed. The solar noon time information provided to controller system **400** assures accuracy making up for other natural parameter changes that can add up into sun tracking error and complications.

Approximation sun tracking as described above provides a practical opportunity to efficiently automate the ability of box solar oven assembly **308** to maintain adequate cooking temperature. This provides the advantage of eliminating the need for feedback (by using an open loop system) from the sun's rays where the sun's rays can be interrupted due to clouds, weather conditions and blowing material such as dust, rain and snow or failure of feedback components.

When a user prefers, approximation sun tracking can be turned off using switch **524** and switch **528**. The user can manually adjust alignment using override button switch **423** and override button switch **426**. Additionally, at any time, the user can non-electric manually adjust alignment using solar altitude override handle **411** and solar azimuth override handle **413** as described earlier.

While above is described approximation sun tracking using open loop without feedback from the strength of the sun's rays, operation of relay switch **531**, relay switch **533** and cross wired relay switch **542** could also be configured based on feedback from the strength of the sun's rays. To implement closed loop sun tracking based on feedback from the strength of the sun's rays, a sensor is used to detect reduction of the detected strength of the sun's rays. Detected reduction passing a particular threshold can result in operation of relay switch **531**, relay switch **533** and relay switch **542**, to reposition box solar oven assembly **308** to maximize the detected strength of the sun's rays.

The positioning system can further be used to put any device on the moveable carriage **58** and have complete articulation of rapid positioning and automatic sun tracking with auto stop when using the controller system **400** electronic controller as fully described above without requiring any electrical wire or component hook up connections to the chosen device type at all. Approximation Tracking and the open loop design allows for extensive versatility of use in the current art.

Another significant advantage of this open loop controller system **400** which uses timer **421** and timer **428** with solar altitude electric motor **401** and solar azimuth electric motor **403** as described above is that any box solar oven **308** automated movement translations in sun tracking can be

accomplished without needing to change the mechanical power transmission ratios (mechanical advantage gear ratios) to achieve different distances of movement. By setting a “Dwell or Wait” time (T1), and the T2 motor run time to different time durations open loop provides a wide range of extensively flexibility to adjust and adapt to various movement distances without requiring changes to the mechanical powered mechanisms to move the box solar oven. This simplifies and lowers cost to adapt to the many different sun path locations, electric motor design ratio and RPM speed selections for manufacturability, and other needed requirements. In the current art, it is perceived that closed loop feedback is the method to control variations in required movement distances and open loop feasibility due to distance variations not easily adjusted to. This novel approach with controller system 400 motor run timing resolves this issue and makes open loop possible to use with the required flexibility.

Further, due to approximation tracking and the open loop design of this positioning system with the controller system 400, no electrical wires need to be connected to the solar radiation collection device at all. This greatly simplifies the automation articulation and movement processes and avoids positioning interferences. This design therefore provides maximum, unimpeded operation flexibility to adapt to the many current art conditions and circumstances.

The foregoing discussion discloses and describes merely exemplary methods and embodiments. As will be understood by those familiar with the art, the disclosed subject matter may be embodied in other specific forms without departing from the spirit or characteristics thereof. Accordingly, the present disclosure is intended to be illustrative, but not limiting, of the scope of the invention.

What is claimed is:

1. A solar oven system, comprising:
  - a solar oven radiation collection device;
  - a structural extension assembly that extends in a radial direction with respect to a structure;
  - a moveable transport that provides linear movement of the solar oven radiation collection device along an axis of the structural extension assembly;
  - a linear deploy electric motor that is used to control linear movement of the solar oven radiation collection device along the axis of the structural extension assembly;
  - a solar altitude electric motor used to adjust orientation of the solar oven radiation collection device to take into account changes in solar altitude with respect to time;
  - a solar azimuth electric motor used to adjust orientation of the solar oven radiation collection device to take into account changes in azimuth with respect to time;
  - a linear deploy override handle that allows an operator to disengage power transmission of linear deploy electric motor and manually adjust linear movement of the solar oven radiation collection device along the axis of the structural extension assembly;
  - a solar altitude override handle that allows an operator to disengage power transmission of solar altitude electric motor and manually adjust position the solar oven radiation collection device for solar altitude;
  - a solar azimuth override handle that allows an operator to disengage power transmission of solar azimuth electric motor and manually adjust position the solar oven radiation collection device for solar altitude;
  - a first timer that controls operation of the solar altitude electric motor to allow positioning of solar oven radiation collection device to take into account changes in sun altitude over cook time;

- a second timer that controls operation of the solar azimuth electric motor to allow positioning of solar oven radiation collection device to take into account changes in sun azimuth over the cook time; and
  - a third timer that reverses direction of solar altitude electric motor upon reaching of solar noon.
2. A solar oven system, comprising:
    - a solar oven radiation collection device;
    - a structural extension assembly that extends in a radial direction with respect to a structure;
    - a moveable transport that provides linear movement of the solar oven radiation collection device along an axis of the structural extension assembly;
    - a linear deploy electric motor that is used to control linear movement of the solar oven radiation collection device along the axis of the structural extension assembly;
    - a solar altitude electric motor used to adjust orientation of the solar oven radiation collection device to take into account changes in solar altitude with respect to time;
    - a solar azimuth electric motor used to adjust orientation of the solar oven radiation collection device to take into account changes in azimuth with respect to time;
    - a linear deploy override handle that allows an operator to disengage power transmission of linear deploy electric motor and manually adjust linear movement of the solar oven radiation collection device along the axis of the structural extension assembly;
    - a solar altitude override handle that allows an operator to disengage power transmission of solar altitude electric motor and manually adjust position the solar oven radiation collection device for solar altitude;
    - a solar azimuth override handle that allows an operator to disengage power transmission of solar azimuth electric motor and manually adjust position the solar oven radiation collection device for solar altitude;
    - a first timer that controls operation of the solar altitude electric motor to allow positioning of solar oven radiation collection device to take into account changes in sun altitude over cook time;
    - a second timer that controls operation of the solar azimuth electric motor to allow positioning of solar oven radiation collection device to take into account changes in sun azimuth over the cook time; and
    - a third timer that stops operation of the solar altitude electric motor and the solar azimuth electric motor when the cook time ends.
  3. A solar oven system as in claim 1, additionally comprising:
    - a fourth timer that stops operation of the solar altitude electric motor and the solar azimuth electric motor when the cook time ends.
  4. A solar oven system, comprising:
    - a solar oven radiation collection device;
    - a structural extension assembly that extends in a radial direction with respect to a structure;
    - a moveable transport that provides linear movement of the solar oven radiation collection device along an axis of the structural extension assembly;
    - a linear deploy electric motor that is used to control linear movement of the solar oven radiation collection device along the axis of the structural extension assembly;
    - a solar altitude electric motor used to adjust orientation of the solar oven radiation collection device to take into account changes in solar altitude with respect to time;
    - a solar azimuth electric motor used to adjust orientation of the solar oven radiation collection device to take into account changes in azimuth with respect to time;

- a linear deploy override handle that allows an operator to disengage power transmission of linear deploy electric motor and manually adjust linear movement of the solar oven radiation collection device along the axis of the structural extension assembly;
  - a solar altitude override handle that allows an operator to disengage power transmission of solar altitude electric motor and manually adjust position the solar oven radiation collection device for solar altitude;
  - a solar azimuth override handle that allows an operator to disengage power transmission of solar azimuth electric motor and manually adjust position the solar oven radiation collection device for solar altitude;
  - a first timer that controls operation of the solar altitude electric motor to allow positioning of solar oven radiation collection device to take into account changes in sun altitude over cook time, wherein the first timer controls the solar altitude electric motor so that positioning of solar oven radiation collection to take into account changes in sun altitude over cook time is done in increments with time durations of inactivity in between; and
  - a second timer that controls operation of the solar azimuth electric motor to allow positioning of solar oven radiation collection device to take into account changes in sun azimuth over the cook time, wherein the second timer controls the solar azimuth electric motor so that positioning of solar oven radiation collection to take into account changes in sun azimuth over cook time is done in increments with time durations of inactivity in between.
5. A solar oven system, comprising:
- a solar oven radiation collection device;
  - a structural extension assembly that extends in a radial direction with respect to a structure;
  - a moveable transport that provides linear movement of the solar oven radiation collection device along an axis of the structural extension assembly;
  - a linear deploy electric motor that is used to control linear movement of the solar oven radiation collection device along the axis of the structural extension assembly;
  - a solar altitude electric motor used to adjust orientation of the solar oven radiation collection device to take into account changes in solar altitude with respect to time;
  - a solar azimuth electric motor used to adjust orientation of the solar oven radiation collection device to take into account changes in azimuth with respect to time;
  - a linear deploy override handle that allows an operator to disengage power transmission of linear deploy electric motor and manually adjust linear movement of the solar oven radiation collection device along the axis of the structural extension assembly;
  - a solar altitude override handle that allows an operator to disengage power transmission of solar altitude electric motor and manually adjust position the solar oven radiation collection device for solar altitude;
  - a solar azimuth override handle that allows an operator to disengage power transmission of solar azimuth electric motor and manually adjust position the solar oven radiation collection device for solar altitude;
  - a first timer that controls operation of the solar altitude electric motor to allow positioning of solar oven radiation collection device to take into account changes in sun altitude over cook time, wherein the first timer controls the solar altitude electric motor so that peri-

- odically position of the solar oven radiation collection is adjusted to take into account changes in sun altitude over cook time; and
  - a second timer that controls operation of the solar azimuth electric motor to allow positioning of solar oven radiation collection device to take into account changes in sun azimuth over the cook time, wherein the second timer controls the solar azimuth electric motor so that periodically position of the solar oven radiation collection is adjusted to take into account changes in sun azimuth over cook time.
6. A solar oven system, comprising:
- a solar oven radiation collection device;
  - a structural extension assembly that extends in a radial direction with respect to a structure;
  - a moveable transport that provides linear movement of the solar oven radiation collection device along an axis of the structural extension assembly;
  - a linear deploy electric motor that is used to control linear movement of the solar oven radiation collection device along the axis of the structural extension assembly;
  - a solar altitude electric motor used to adjust orientation of the solar oven radiation collection device to take into account changes in solar altitude with respect to time;
  - a solar azimuth electric motor used to adjust orientation of the solar oven radiation collection device to take into account changes in azimuth with respect to time;
  - a first timer that controls operation of the solar altitude electric motor to allow positioning of solar oven radiation collection device to take into account changes in sun altitude over cook time;
  - a second timer that controls operation of the solar azimuth electric motor to allow positioning of solar oven radiation collection device to take into account changes in sun azimuth over the cook time; and
  - a third timer that reverses direction of solar altitude electric motor upon reaching of solar noon.
7. A solar oven system, comprising:
- a solar oven radiation collection device;
  - a structural extension assembly that extends in a radial direction with respect to a structure;
  - a moveable transport that provides linear movement of the solar oven radiation collection device along an axis of the structural extension assembly;
  - a linear deploy electric motor that is used to control linear movement of the solar oven radiation collection device along the axis of the structural extension assembly;
  - a solar altitude electric motor used to adjust orientation of the solar oven radiation collection device to take into account changes in solar altitude with respect to time;
  - a solar azimuth electric motor used to adjust orientation of the solar oven radiation collection device to take into account changes in azimuth with respect to time;
  - a first timer that controls operation of the solar altitude electric motor to allow positioning of solar oven radiation collection device to take into account changes in sun altitude over cook time;
  - a second timer that controls operation of the solar azimuth electric motor to allow positioning of solar oven radiation collection device to take into account changes in sun azimuth over the cook time; and
  - a third timer that stops operation of the solar altitude electric motor and the solar azimuth electric motor when the cook time ends.

31

8. A solar oven system as in claim 6, additionally comprising:
- a fourth timer that stops operation of the solar altitude electric motor and the solar azimuth electric motor when the cook time ends.
9. A solar oven system, comprising:
- a solar oven radiation collection device;
  - a structural extension assembly that extends in a radial direction with respect to a structure;
  - a moveable transport that provides linear movement of the solar oven radiation collection device along an axis of the structural extension assembly;
  - a linear deploy electric motor that is used to control linear movement of the solar oven radiation collection device along the axis of the structural extension assembly;
  - a solar altitude electric motor used to adjust orientation of the solar oven radiation collection device to take into account changes in solar altitude with respect to time;
  - a solar azimuth electric motor used to adjust orientation of the solar oven radiation collection device to take into account changes in azimuth with respect to time;
  - a first timer that controls operation of the solar altitude electric motor to allow positioning of solar oven radiation collection device to take into account changes in sun altitude over cook time, wherein the first timer controls the solar altitude electric motor so that positioning of solar oven radiation collection to take into account changes in sun altitude over cook time is done in increments with time durations of inactivity in between; and
  - a second timer that controls operation of the solar azimuth electric motor to allow positioning of solar oven radiation collection device to take into account changes in sun azimuth over the cook time, wherein the second timer controls the solar azimuth electric motor so that positioning of solar oven radiation collection to take into account changes in sun azimuth over cook time is done in increments with time durations of inactivity in between.
10. A solar oven system, comprising:
- a solar oven radiation collection device;
  - a structural extension assembly that extends in a radial direction with respect to a structure;
  - a moveable transport that provides linear movement of the solar oven radiation collection device along an axis of the structural extension assembly;
  - a linear deploy electric motor that is used to control linear movement of the solar oven radiation collection device along the axis of the structural extension assembly;
  - a solar altitude electric motor used to adjust orientation of the solar oven radiation collection device to take into account changes in solar altitude with respect to time;
  - a solar azimuth electric motor used to adjust orientation of the solar oven radiation collection device to take into account changes in azimuth with respect to time;
  - a first timer that controls operation of the solar altitude electric motor to allow positioning of solar oven radiation collection device to take into account changes in sun altitude over cook time, wherein the first timer controls the solar altitude electric motor so that periodically position of the solar oven radiation collection is adjusted to take into account changes in sun altitude over cook time; and
  - a second timer that controls operation of the solar azimuth electric motor to allow positioning of solar oven radiation collection device to take into account changes in sun azimuth over the cook time, wherein the second

32

- timer controls the solar azimuth electric motor so that periodically position of the solar oven radiation collection is adjusted to take into account changes in sun azimuth over cook time.
11. A positioning system that positions a solar oven radiation collection device, the positioning system, comprising:
- a structural extension assembly that extends in a radial direction with respect to a structure;
  - a moveable transport that provides linear movement of the solar oven radiation collection device along an axis of the structural extension assembly;
  - a linear deploy electric motor that is used to control linear movement of the solar oven radiation collection device along the axis of the structural extension assembly;
  - a solar altitude electric motor used to adjust orientation of the solar oven radiation collection device to take into account changes in solar altitude with respect to time;
  - a solar azimuth electric motor used to adjust orientation of the solar oven radiation collection device to take into account changes in azimuth with respect to time;
  - a linear deploy override handle that allows an operator to disengage power transmission of linear deploy electric motor and manually adjust linear movement of the solar oven radiation collection device along the axis of the structural extension assembly;
  - a solar altitude override handle that allows an operator to disengage power transmission of solar altitude electric motor and manually adjust position the solar oven radiation collection device for solar altitude;
  - a solar azimuth override handle that allows an operator to disengage power transmission of solar azimuth electric motor and manually adjust position the solar oven radiation collection device for solar altitude;
  - a first timer that controls operation of the solar altitude electric motor to allow positioning of solar oven radiation collection device to take into account changes in sun altitude over cook time; and
  - a second timer that controls operation of the solar azimuth electric motor to allow positioning of solar oven radiation collection device to take into account changes in sun azimuth over the cook time.
12. A positioning system as in claim 11, additionally comprising:
- a third timer that reverses direction of solar altitude electric motor upon reaching of solar noon.
13. A solar oven system as in claim 11, additionally comprising:
- a third timer that stops operation of the solar altitude electric motor and the solar azimuth electric motor when the cook time ends.
14. A positioning system as in claim 11, additionally comprising:
- a third timer that reverses direction of solar altitude electric motor upon reaching of solar noon; and
  - a fourth timer that stops operation of the solar altitude electric motor and the solar azimuth electric motor when the cook time ends.
15. A positioning system, comprising:
- a structural extension assembly that extends in a radial direction with respect to a structure;
  - a moveable transport that provides linear movement of the solar oven radiation collection device along an axis of the structural extension assembly;
  - a linear deploy electric motor that is used to control linear movement of the solar oven radiation collection device along the axis of the structural extension assembly;

- a solar altitude electric motor used to adjust orientation of the solar oven radiation collection device to take into account changes in solar altitude with respect to time;
  - a solar azimuth electric motor used to adjust orientation of the solar oven radiation collection device to take into account changes in azimuth with respect to time;
  - a linear deploy override handle that allows an operator to disengage power transmission of linear deploy electric motor and manually adjust linear movement of the solar oven radiation collection device along the axis of the structural extension assembly;
  - a solar altitude override handle that allows an operator to disengage power transmission of solar altitude electric motor and manually adjust position the solar oven radiation collection device for solar altitude;
  - a solar azimuth override handle that allows an operator to disengage power transmission of solar azimuth electric motor and manually adjust position the solar oven radiation collection device for solar altitude;
  - a first timer that controls operation of the solar altitude electric motor to allow positioning of solar oven radiation collection device to take into account changes in sun altitude over cook time, wherein the first timer controls the solar altitude electric motor so that positioning of solar oven radiation collection to take into account changes in sun altitude over cook time is done in increments with time durations of inactivity in between; and
  - a second timer that controls operation of the solar azimuth electric motor to allow positioning of solar oven radiation collection device to take into account changes in sun azimuth over the cook time, wherein the second timer controls the solar azimuth electric motor so that positioning of solar oven radiation collection to take into account changes in sun azimuth over cook time is done in increments with time durations of inactivity in between.
16. A positioning system, comprising:
- a structural extension assembly that extends in a radial direction with respect to a structure;

- a moveable transport that provides linear movement of the solar oven radiation collection device along an axis of the structural extension assembly;
- a linear deploy electric motor that is used to control linear movement of the solar oven radiation collection device along the axis of the structural extension assembly;
- a solar altitude electric motor used to adjust orientation of the solar oven radiation collection device to take into account changes in solar altitude with respect to time;
- a solar azimuth electric motor used to adjust orientation of the solar oven radiation collection device to take into account changes in azimuth with respect to time;
- a linear deploy override handle that allows an operator to disengage power transmission of linear deploy electric motor and manually adjust linear movement of the solar oven radiation collection device along the axis of the structural extension assembly;
- a solar altitude override handle that allows an operator to disengage power transmission of solar altitude electric motor and manually adjust position the solar oven radiation collection device for solar altitude;
- a solar azimuth override handle that allows an operator to disengage power transmission of solar azimuth electric motor and manually adjust position the solar oven radiation collection device for solar altitude;
- a first timer that controls operation of the solar altitude electric motor to allow positioning of solar oven radiation collection device to take into account changes in sun altitude over cook time, wherein the first timer controls the solar altitude electric motor so that periodically position of the solar oven radiation collection is adjusted to take into account changes in sun altitude over cook time; and
- a second timer that controls operation of the solar azimuth electric motor to allow positioning of solar oven radiation collection device to take into account changes in sun azimuth over the cook time, wherein the second timer controls the solar azimuth electric motor so that periodically position of the solar oven radiation collection is adjusted to take into account changes in sun azimuth over cook time.

\* \* \* \* \*